



KEY SWITCH AND COVER INCLUDED  
2x4x 2 1/2 BOX NOT INCLUDED

**ELECTRICAL DATA**

- 2HP GEAR-MOTOR, 3PH 60HZ W/BRAKE
  - 208 VAC, 6.1 A      □ 230 VAC, 5.9 A
  - 460 VAC, 3.5 A

-INCLUDES A KEY SWITCH AND 2x4 BOX COVER. A 2x4x2<sup>1</sup>/<sub>2</sub>"d JUNCTION BOX SUPPLIED BY OTHERS.

-FUSED DISCONNECT SUPPLIED BY OTHERS. ALL WIRING AND RECEPTICLES SUPPLIED BY OTHER.

-CORRECT MOTOR ROTATION MUST BE VERIFIED BY ELECTRICAL CONTRACTOR DURING ELECTRICAL INSTALLATION. REVIEW INSTALLATION MANUAL FOR IMPORTANT INSTRUCTIONS.

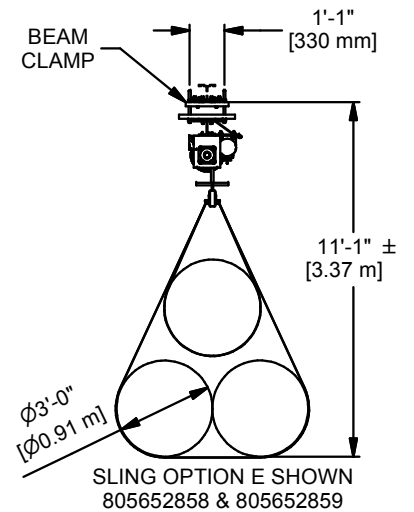
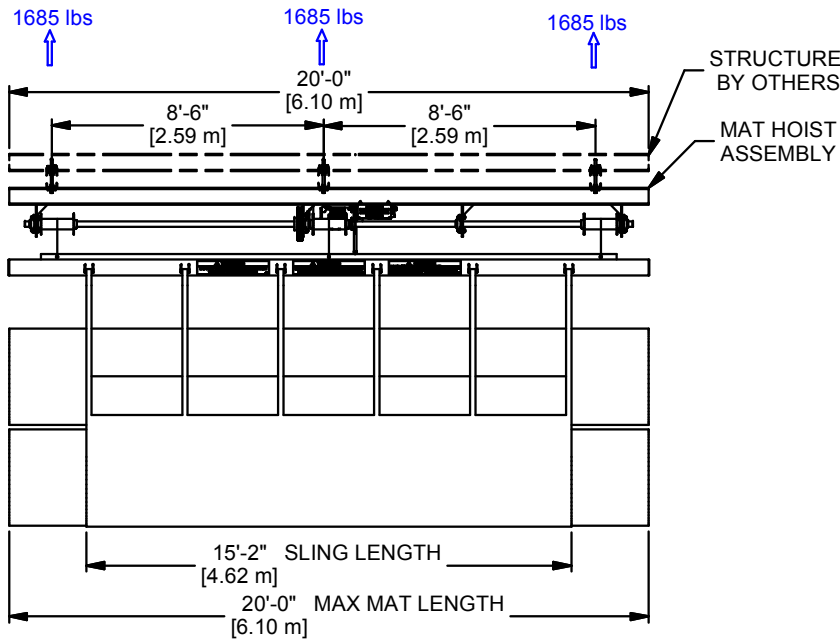
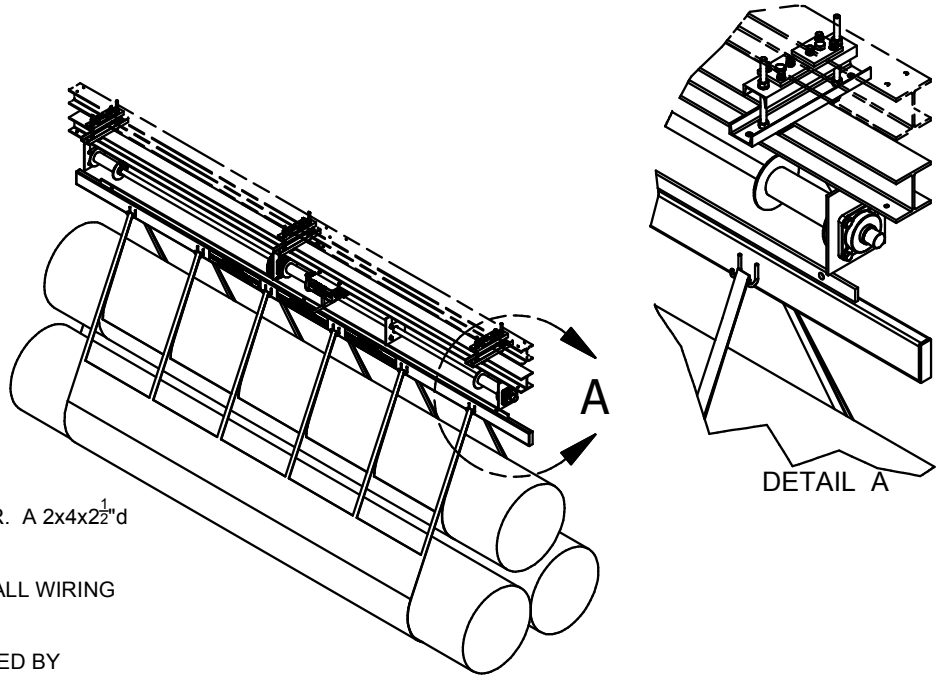

**NOTES:**

- STRUCTURE SUPPLIED BY OTHERS TO BE FIELD VERIFIED BEFORE PRODUCTION.
- KEY SWITCH MUST BE LOCATED IN AN AREA THAT ALLOWS THE HOIST TO BE VISIBLE TO THE OPERATOR, BUT CLEAR OF THE MAT LOAD.

	WEIGHT (lbs)
MAT HOIST ASSY	1,200
LOAD BAR & SLING	355
ROLLED MAT (maximum)*	3,500
<b>TOTAL</b>	<b>5,055</b>

\*TOTAL MAT LENGTH NOT TO EXCEED 20'

D	WDC	3-28-16
REV	BY	DATE



Gared Holdings, LLC  
9200 E. 146th St.      Noblesville, IN 46060

THIS DOCUMENT CONTAINS TRADE SECRET AND OTHER MATERIALS WHICH ARE PROTECTED BY CONFIDENTIALITY NOTICE AND AGREEMENT AND BY COPYRIGHT. ANY USE OR COPYING OF THIS DOCUMENT EXCEPT AS AUTHORIZED BY GARED HOLDINGS, LLC IS STRICTLY PROHIBITED.

**MAT HOIST, 20' DBL LOAD BAR, STATIONARY**

DRAWN	CROSBY	DATE	3/28/2016	DATE ISSUED
APPROVED		DATE		
FILE LOC. Q:\Inventor Files\Specification Files\10_Curtains				
SIZE	SCALE	SHT. NO.	PART NO.	REV
A		1 OF 4	4091-DS	D

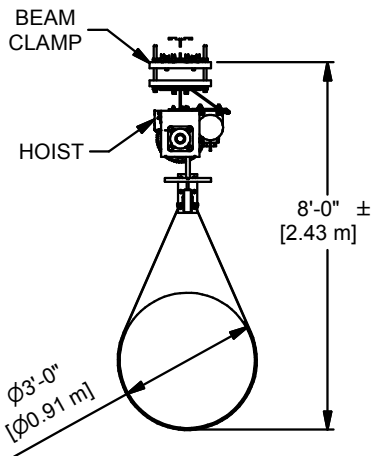

SLING OPTION A  
805652859

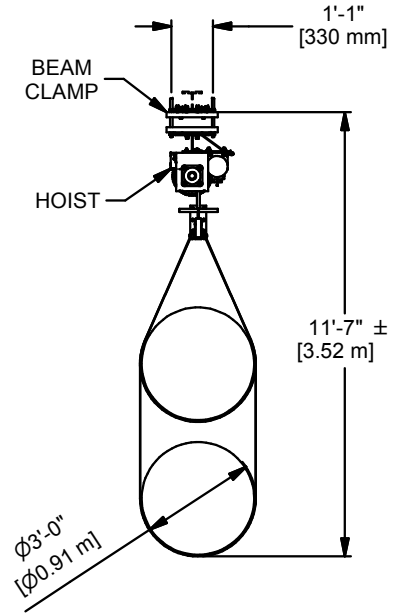

SLING OPTION B  
805652859 & 805652860

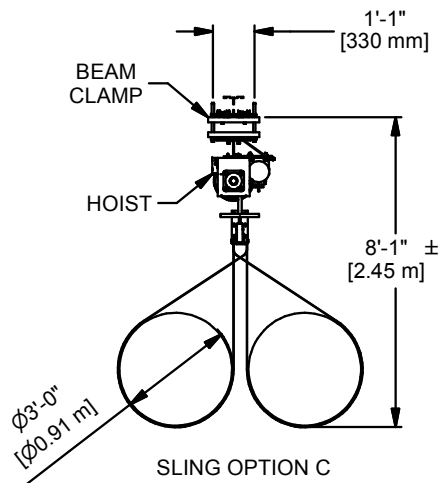

SLING OPTION C  
(2) 805652859

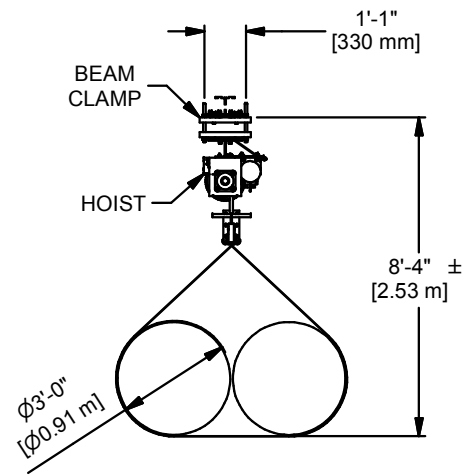

SLING OPTION D  
CUSTOM

D	WDC	3-28-16
REV	BY	DATE



Gared Holdings, LLC  
9200 E. 146th St. Noblesville, IN 46060

THIS DOCUMENT CONTAINS TRADE SECRET AND OTHER MATERIALS WHICH ARE PROTECTED BY CONFIDENTIALITY NOTICE AND AGREEMENT AND BY COPYRIGHT. ANY USE OR COPYING OF THIS DOCUMENT EXCEPT AS AUTHORIZED BY GARED HOLDINGS, LLC IS STRICTLY PROHIBITED.

**MAT SLING CHART**

DRAWN	CROSBY	DATE	3/28/2016	DATE ISSUED
APPROVED		DATE		

FILE LOC. Q:\Inventor Files\Specification Files\10\_Curtains

SIZE	SCALE	SHT. NO.	PART NO.	REV
A		2 OF 4	4091-DS	D



**MODEL 4091-DS**  
**WRESTLING MAT STORAGE SYSTEM**  
**WITH 20' LOAD BAR FOR DOUBLE SLING**

**RECOMMENDED APPLICATION**

This unit allows user to gain storage space and reduce risk of injuries to students and coaches. Simply roll the mat into the vinyl sling, attach it to the load bar and turn the key. The mats are easily raised and stored at ceiling height. The 4091-DS wrestling mat storage system lifts one to three mat rolls up to 20 ft long and can be easily mounted in most gyms.

**SPECIFICATIONS**

**OVERHEAD SUPERSTRUCTURE**

The model 4091-DS Wrestling Mat Storage System is supported from the roof structure by directly attaching a W6 x 25 I-beam to the underneath side of the roof truss or by attaching to additional beams supplied by general contractor. The supplied beam must be level. The minimum length of supplied beam is to be 20' clear of obstructions.

**DRIVE / SUPPORT STRUCTURE**

Drive and spools are attached to a W6 x 25 I-beam frame weldment for rigid support. A one piece 2" solid keyed drive shaft runs on four self-aligning machined ball bearing pillow blocks. Unit includes three 4" diameter cable drums to prolong cable life. Lifting rate shall be 13.6 fpm. Finish shall be black power coat. Unit is shipped upright on metal stands for safer installation.

The model 4091-DS Wrestling Mat Storage System shall be operated by a 2 horsepower, 3ph reversible motor available for connection to 208, 230, or 460 VAC power. Unit includes a 48 to 1 industrial in-line helical gear speed reducer and a 20-ft./lbs. electric brake.

Motor controls include motor reversing contactors and motor overload protection. Fused disconnect is to be provided by others. An audible alarm shall sound when unit is operating. A key switch and 2x4" switch cover is included. Key switch must be located in an area that allow the hoist to be visible to the operator, but clear of the mat load. Limit switches shall control the up and the down travel and a second up limit switch shall be included for extra safety. Controls are shipped attached to the hoist frame and are factory wired and tested.

A 20' long, welded 2" x 6" rectangular load bar is raised by three 5/16" galvanized carbon steel aircraft grade cables. Cables shall have a ultimate load rating of 9800 lbs each. Load bar shall be equipped with steel hooks to accommodate "D" rings on sling straps.

**SLING**

Mat sling shall be constructed of 18-ounce vinyl with twelve 2" wide nylon straps that wrap all the way around the sling. Nylon straps to have 7000# braking strength and "D" rings and self-closing hooks at end of strap. Four sling configurations are available.

**OPTIONS**

155655941 MAT HOIST SAFETY STRAP PACKAGE (includes (2) 1109 Mat Locks)  
801703914 RELAY BOX ASSY (for use with TSC2000 series control system)

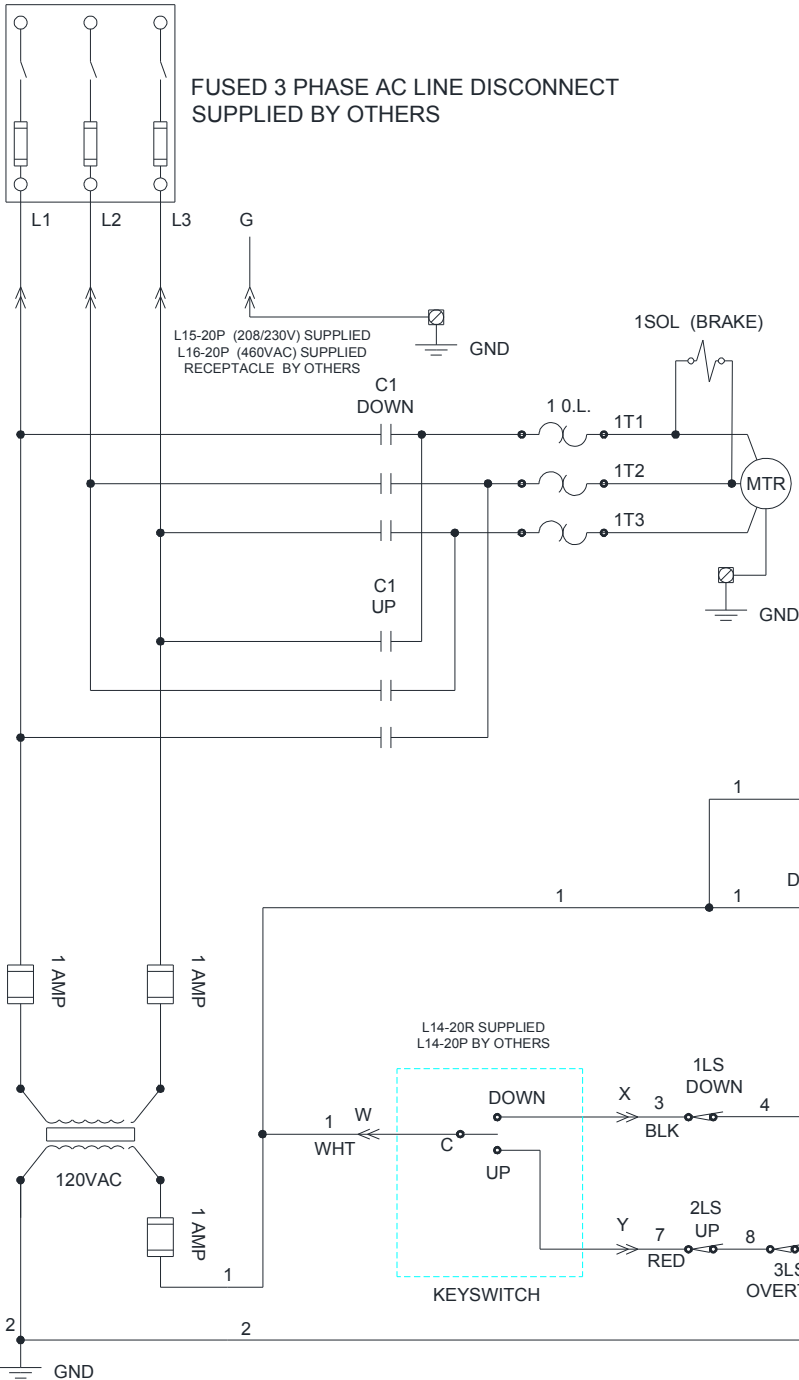

2 HP 3PH 60HZ MOTOR DATA	
VOLTAGE	FLA (AMPS)
208 V	6.1
230 V	5.9
480 V	3.5

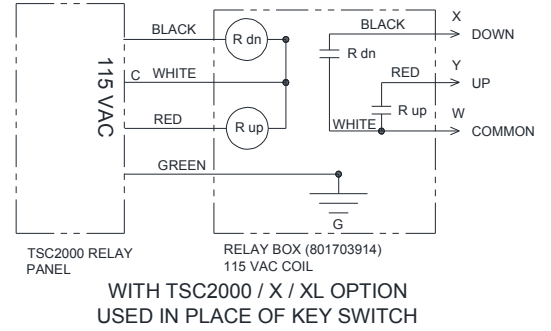

- CONNECTORS ON CONTROL BOX SUPPLIED WITH 6' CORD. MATING CONNECTORS SUPPLIED BY OTHERS.
- ROTATION MUST BE SET BY THE ELECTRICAL CONTRACTOR AT FIELD STARTUP. CHANGE ROTATION AT THE SUPPLY CONNECTION, NOT AT THE KEY SWITCH CONNECTION. CHANGING ROTATION AT KEY SWITCH CAN CAUSE SERIOUS DAMAGE. REVIEW INSTRUCTIONS IN INSTALLATION MANUAL.

D	WDC	3-28-16
REV	BY	DATE



Gared Holdings, LLC  
9200 E. 146th St. Noblesville, IN 46060

THIS DOCUMENT CONTAINS TRADE SECRET AND OTHER MATERIALS WHICH ARE PROTECTED BY CONFIDENTIALITY NOTICE AND AGREEMENT AND BY COPYRIGHT. ANY USE OR COPYING OF THIS DOCUMENT EXCEPT AS AUTHORIZED BY GARED HOLDINGS, LLC IS STRICTLY PROHIBITED.

**MAT HOIST WIRING SCHEMATIC 3PH POWER**

DRAWN	CROSBY	DATE	3/28/2016	DATE ISSUED
APPROVED		DATE		
FILE LOC. Q:\Inventor Files\Specification Files\10_Curtains				
SIZE	SCALE	SHT. NO.	PART NO.	REV
A		4 OF 4	4091-DS	D