

GOAL HT.	DIM "A"	DIM "B"	DIM "C"
10'-0" [3.048 m]	10'-8" [3.251 m]	13'-3" [4.039 m]	15'-1 3/8" [4.607 m]
9'-0" [2.743 m]	7'-4 1/2" [2.248 m]	9'-11 1/2" [3.035 m]	11'-9 7/8" [3.604 m]
8'-0" [2.438 m]	6'-3 7/8" [1.927 m]	8'-10 7/8" [2.715 m]	10'-9 1/4" [3.283 m]

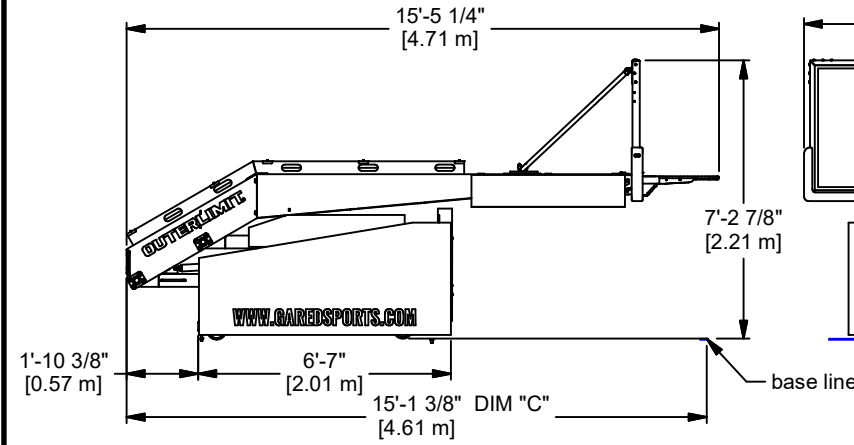

**STORED DIMENSIONS**

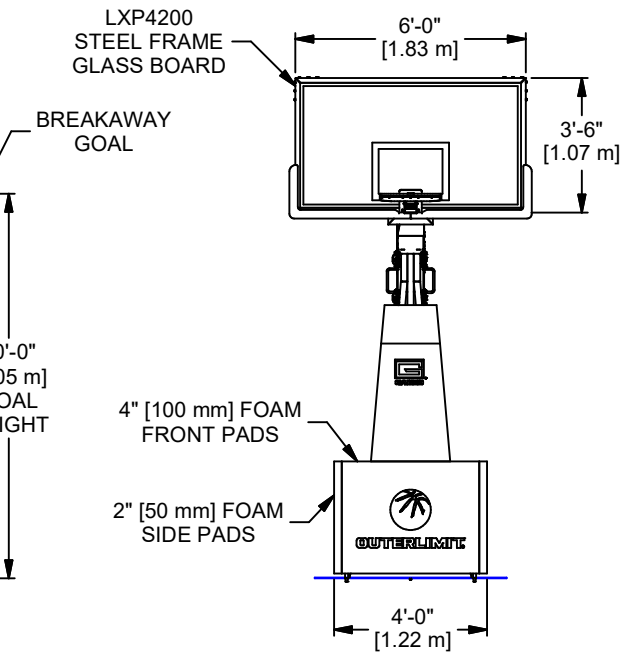
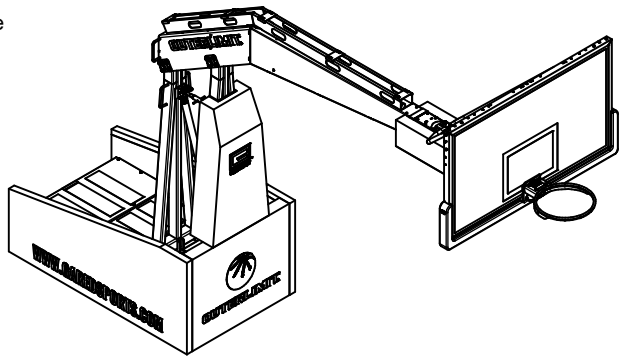
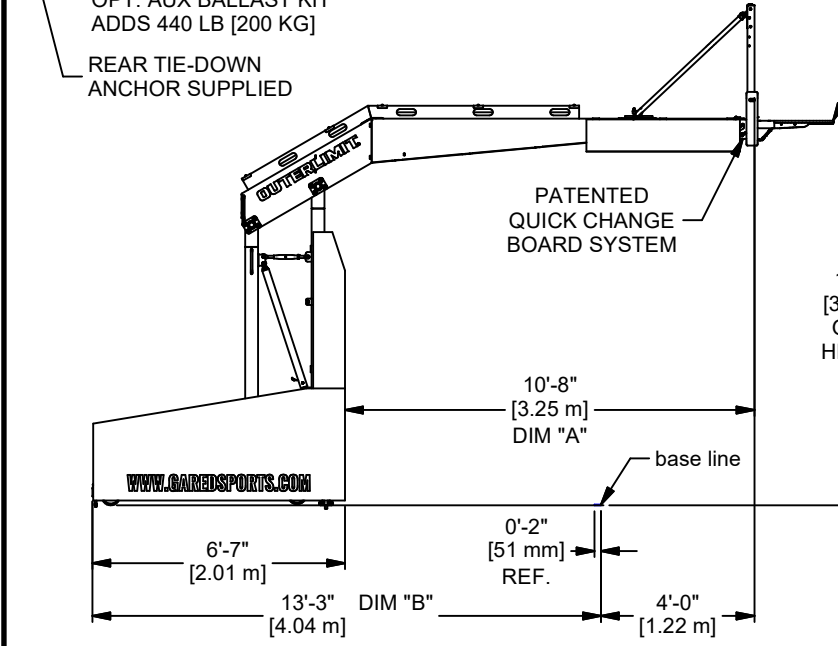
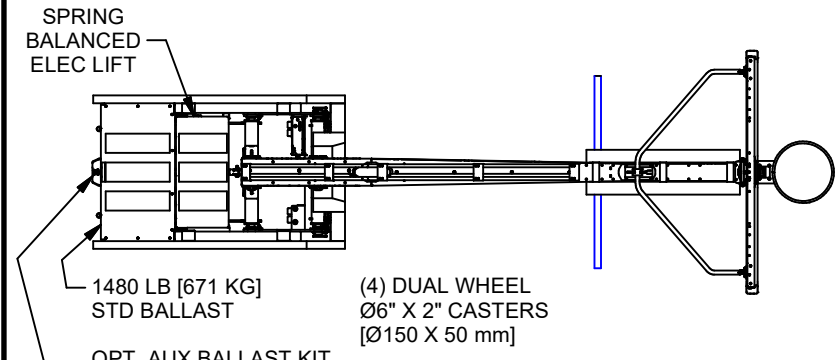

A	ERD	08-04-23
REV	BY	DATE

**G GARED PERFORMANCE SPORTS SYSTEMS**

Gared Performance Sports Systems  
9200 East 146th Street, Suite A  
Noblesville, IN 46060

THIS DOCUMENT CONTAINS TRADE SECRET AND OTHER MATERIALS WHICH ARE PROTECTED BY CONFIDENTIALITY NOTICE AND AGREEMENT AND BY COPYRIGHT. ANY USE OR COPYING OF THIS DOCUMENT EXCEPT AS AUTHORIZED BY GARED PERFORMANCE SPORTS SYSTEMS IS STRICTLY PROHIBITED.

**PORTABLE, OUTER LIMIT PRO 10-8" ELEC**

DRAWN CROSBY	DATE 10/7/2021	DATE ISSUED
APPROVED	DATE	

SIZE <b>A</b>	SCALE	SHT. NO. 1 OF 2	PART NO. <b>9718E</b>	REV <b>A</b>
------------------	-------	--------------------	--------------------------	-----------------



**OUTER LIMIT PRO MODEL 9718E**  
**PORTABLE BASKETBALL GOAL**

The Outer Limit Pro portable goal is designed for competition, arena play with a 10'-8" extension. This unit meets requirements of NBA, NCAA, NFHA and is approved by FIBA for level 1 competition.

**FRAME**

The base frame shall be constructed of 3" x 5" tubing and ½" steel plate welded to form a single unitized frame. The front and rear arms shall be constructed of 4" x 4" tubular steel welded to form a unitized frame. The main boom and boom extension shall be constructed of a fabricated 13 ¾ x 8 ½" tapered beam. The backboard shall be supported by a direct mounting through the goal to the main boom and a 1 5/16" diameter formed tube brace to the upper corners of the board. The base shall have adjustable, slip resistant leveling bar to support the front during play.

**BALLAST**

An additional 1480 lbs steel bar ballast is included with the standard unit. The total unit playing weight, including ballast, is 3575 lbs. An auxiliary ballast box is optional to increase the ballast when required.

**WHEELS**

Each unit shall be transported on (4) dual wheel swivel casters, constructed with (2) 6" x 2" non-marking polyurethane treads. Each dual wheeled caster shall have precision bearings and be rated for 3400 lbs each. The rear wheel caster shall have a selectable locking swivel feature to increase maneuverability.

**FINISH**

Each unit shall be finished in a black powder coat enamel finish. Optional colors available on request.

**PADDING**

Main vertical arms and front face area shall be padded with a minimum of 4" thick heavy-duty polyurethane foam and covered with a black 14-ounce tear resistant, mildew resistant vinyl. Side padding shall be 2" thick Polyurethane foam. All padding shall be attached in a manner for quick replacement.

**FOLDING CYCLE (electric actuated)**

Each unit shall have (8) heavy duty, adjustable tension springs hidden under the base to counterbalance boom weight. Standard springs are provided to lift a 105 lb optional shot clock. Additional lifting springs available for heavier loads. An electric actuator, with remote control and key control, lifts and lowers unit into position. Actuator requires a 115v 1ph 60hz 5amp or 220v 1ph 50 hz 3.5amp outlet. A telescoping locking bar with safety locking pin shall be used to hold the unit in full up and full down position or at 8' or 9' goal heights. At the 10' position, a horizontal locking bar shall be provided for maximum stability. The adjustable leveling bar shall automatically lift the front wheels from the floor as the unit is lifted.

**BACKBOARD & GOAL**

The Outer Limit Pro shall be supplied with model LXP4200 72" x 42", ½" thick glass board constructed with a welded steel frame. The board shall be mounted by a patented quick change attachment system. The goal supplied shall be model 2000+, a positive lock, breakaway goal or as specified with order. PMCE board padding shall be included.

Subject to design change and current manufacturing practices.  
©2008 Gared Performance Sports Systems, LLC

