

PARTS LIST			
ITEM	QTY	PART NUMBER	DESCRIPTION
1	4	502-6-16-16	HEX BOLT, 3/8-16 UNC X 1
2	1	2-04-15-1	HARDWARE KIT, 15-1
3	1	853853016	GSUAP RH ANGLE BRKT
4	1	853853017	GSUAP LH ANGLE BRKT
5	1	853853043	GSUAP BASE PLATE

NOTE: HARDWARE IS ZINC-PLATED, GR 5

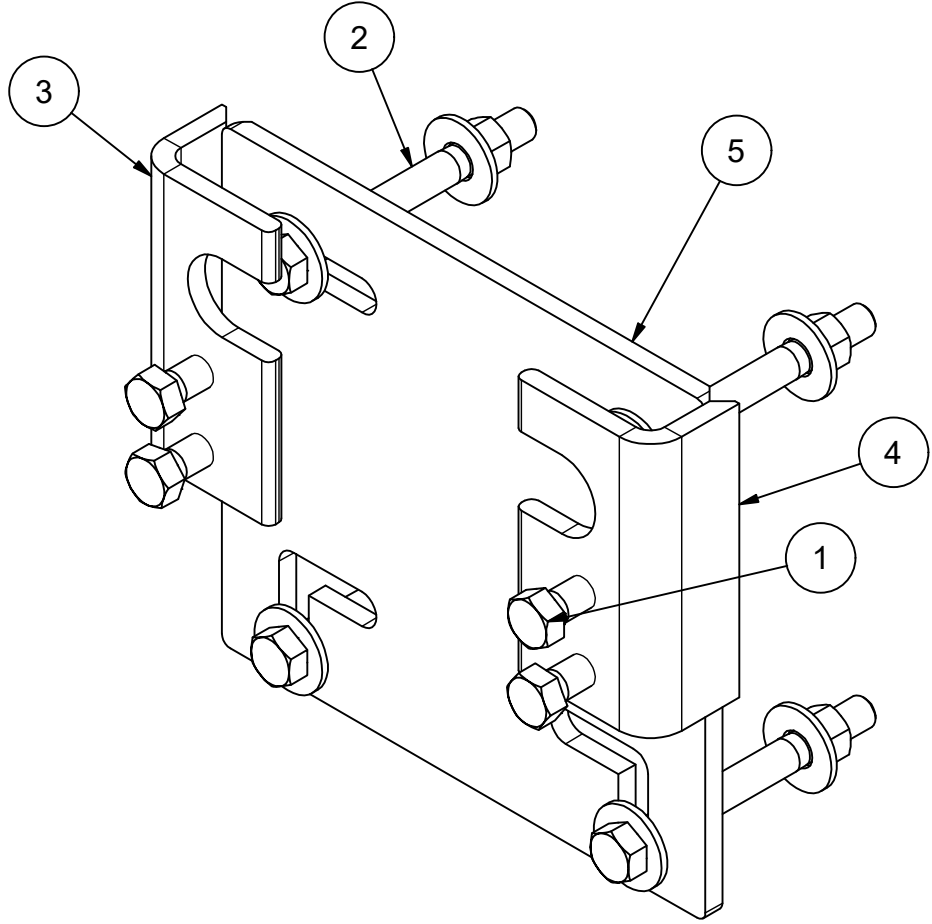
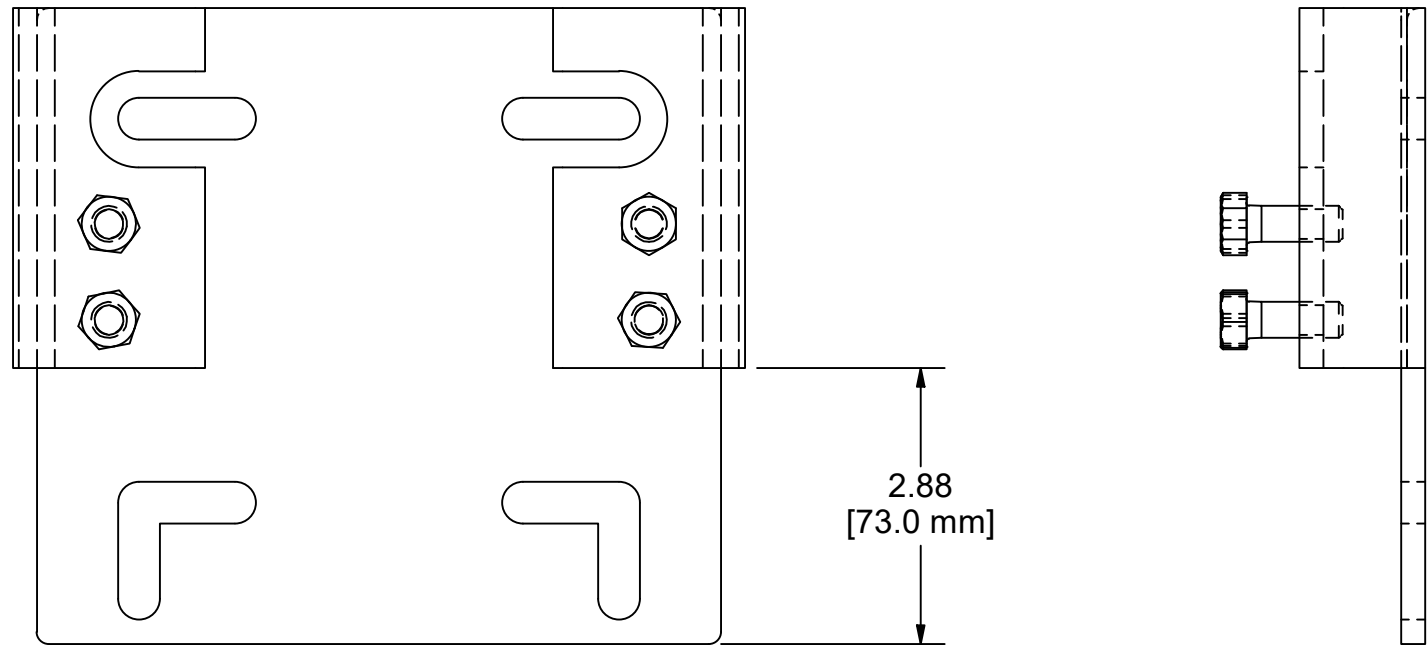
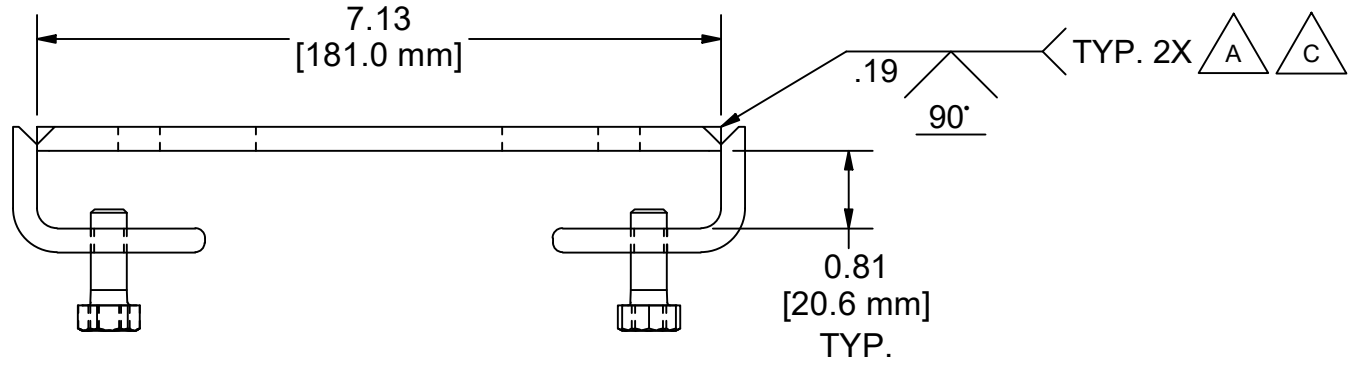

FINISHED WEIGHT 5.384 lbmass

REV	BY	DATE	ECN	REVISION DESCRIPTION
C	AP	6/15/23	0169	UPDATE VIEWS; CHANGE WELD CALLOUT; REMOVE EDGE PROFILE NOTE; REPLACE ITEMS 1 & 2; ADD HARDWARE NOTE
B	MJP	5/15/19		ADD HARDWARE KIT
A	MJP	2/27/19		ADDED NOTES AND WELD PENETRATION DEPTH

UNLESS OTHERWISE SPECIFIED  
DIMENSIONS ARE IN INCHES  
[XX.XX] DIMENSIONS ARE IN MM  
TOLERANCES ARE:  
.X ± 0.060 [1.50 mm]  
.XX ± 0.030 [0.75 mm]  
.XXX ± 0.010 [0.25 mm]  
ANGLES  
X. = 1°  
X.X = 1/2°

THIRD ANGLE PROJECTION

Gared Holdings, LLC  
9200 E. 146th St. Noblesville, IN 46060

THIS DOCUMENT CONTAINS TRADE SECRET AND OTHER MATERIALS WHICH ARE PROTECTED BY CONFIDENTIALITY NOTICE AND AGREEMENT AND BY COPYRIGHT. ANY USE OR COPYING OF THIS DOCUMENT EXCEPT AS AUTHORIZED BY GARED HOLDINGS, LLC IS STRICTLY PROHIBITED.

**UNIVERSAL ADAPTER PLATE**

DRAWN	CROSBY	DATE	1/25/2019	MATERIAL	SEE PARTS LIST
APPROVED		DATE		FINISH	POWDER COAT ORANGE
FILE LOC.	Q:\Inventor Files\850,000,000			DWG. NO.	
SIZE	SCALE	SHT. NO.	PART NO.	REV	
B		1 OF 1	GSUAP	C	