

WEIGHT W/O BACKBOARD.....260 lbs [118 kg]  
 WEIGHT WITH (1) BACKBOARD.....497 lbs [225 kg]  
 WEIGHT WITH (2) BACKBOARDS.....734 lbs [333 kg]

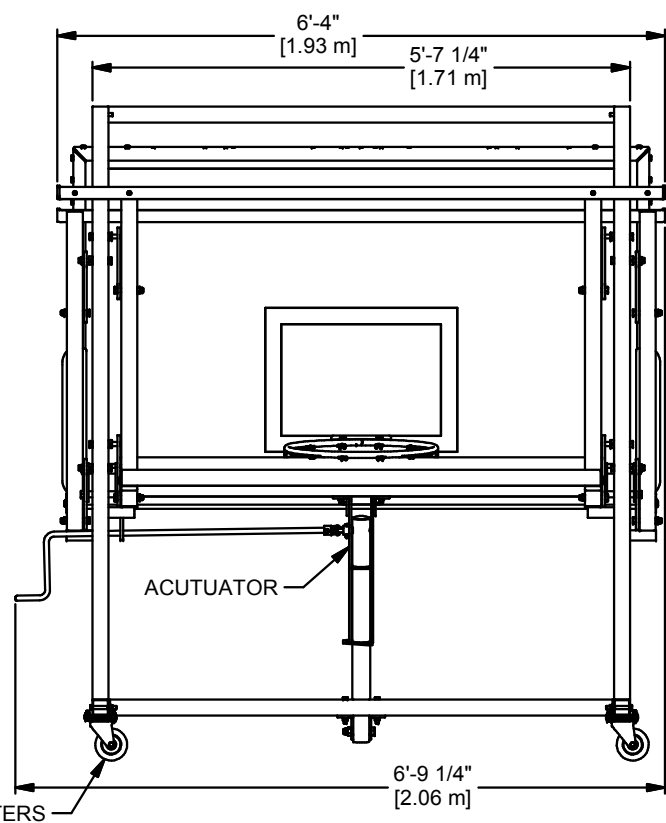
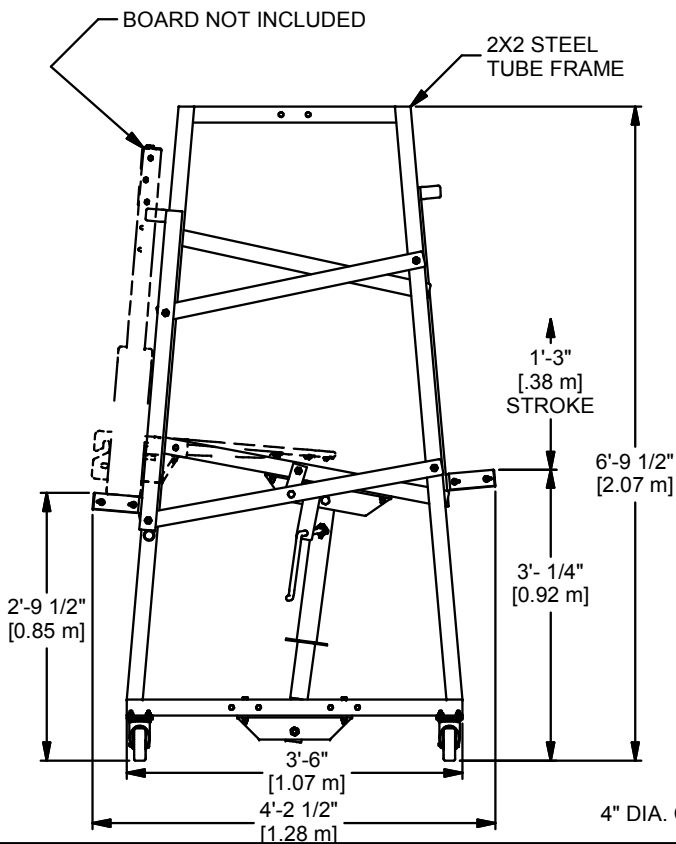
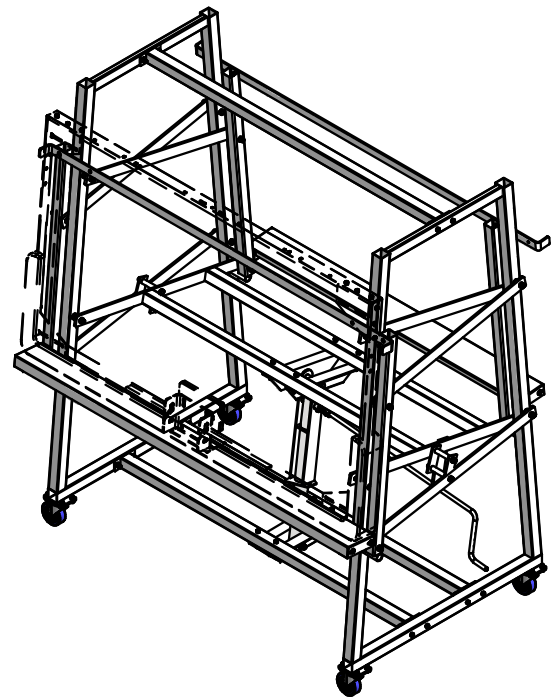

THIS DOCUMENT CONTAINS TRADE SECRET AND OTHER MATERIALS WHICH ARE PROTECTED BY CONFIDENTIALITY NOTICE AND AGREEMENT AND BY COPYRIGHT. ANY USE OR COPYING OF THIS DOCUMENT EXCEPT AS AUTHORIZED BY GARED HOLDINGS, LLC IS STRICTLY PROHIBITED.

**QUICK CONNECT CART**

DRAWN	CROSBY	DATE	11/17/2014	DATE ISSUED
APPROVED		DATE		

FILE LOC. Q:\Inventor Files\Specification Files\02\_Portables

SIZE	SCALE	SHT. NO.	PART NO.	REV
A		1 OF 2	9800	A



Gared Holdings, LLC  
 9200 E. 146th St. Noblesville, IN 46060

A	WDC	11-17-14
REV	BY	DATE



## Model 9800

### Quick Connect™ Cart

#### **GENERAL**

The GARED® Quick Connect™ Cart is a specially designed mechanized cart that allows arena managers to store and quickly transport glass backboards. Further, the cart provides a mechanism to quickly lift into place a replacement glass backboard either during maintenance or an emergency situation. Replacing a backboard with the cart requires about three minutes, a task that typically takes about one hour.

In the event of a malfunction, the Quick Connect™ Cart simplifies the process by allowing for rapid replacement of the malfunctioning backboard instead of removing and replacing the entire portable unit.

#### **FRAME**

The main frame shall be constructed of 2" square tubing to form a single heavy duty unitized frame. The lifting frame shall be constructed of heavy gauge steel.

#### **LIFT ACTUATOR**

Each unit shall have a screw type actuator capable of lifting 1000 pounds. To connect the lift frame to the main frame

#### **WHEELS**

The cart shall have four 4" diameter swivel casters for ease of movement. The casters shall be supported on permanently lubricated bearings and shall be equipped a non-marking wheel.

#### **FINISH**

Each unit shall be finished in a white powder coat enamel finish. Custom colors are available upon request.