



Top Roll Divider Curtain

Models: 4040 (Single Motor) and 4040 (Dual Motor)



Installation, Operation and Maintenance Instructions

.....
Please read all instructions before attempting installation or operation of these units
.....

SAVE THESE INSTRUCTIONS FOR FUTURE USE

PUBLICATION No.
7 0 1 7 5 5 3 4 4 rev4

Revised
Aug 25, 2016



Table of Contents

<u>Section</u>	<u>Page No.</u>
Introduction	2
Cautions and Warnings	3
Parts Checklist (For Drop Mounted Carriers ONLY)	4
Parts Checklist (For Direct Mounted Carriers ONLY)	5
Tools Required	6
Installing Overhead Structure (Common to both Single Motor and Dual Motor)	7
Attaching Curtain Vinyl (Common to both Single Motor and Dual Motor)	10
Installing the bottom Batten (Common to both Single Motor and Dual Motor)	11
Raising Curtain to Overhead (Common to both Single Motor and Dual Motor)	11
Installing the Drive Motor(s)	13
Installing the Idler (Single Motor Drive ONLY)	15
Installing End Brackets (Single Motor Drive ONLY)	16
Installing End Brackets (Dual Motor Drive ONLY)	16
Temporary Wiring	17
Setting Motor Limits	17
Permanent Wiring	19
Wiring Diagram	21
Operation Guidelines	24
Maintenance	26
Product Registration Form	27



Top Roll Divider Curtain



Introduction

Thank you for your purchase of a Model 4040 Top Roll Divider Curtain. To ensure that our equipment will provide years of use to you, we are including this installation, operation, and maintenance guide. This guide will provide information on the proper assembly and installation methods, operating procedures, and preventative maintenance of your gymnasium divider curtain.

Please note that a Bill of Materials is being included with this guide. Please check that all of the parts called out on the Bill of Materials are present prior to beginning assembly and setup. Please do not substitute for factory parts. Please contact the PSS or Gared Sports customer service department and allow them to determine if substitute parts are acceptable.

It is recommended that an individual who has been properly trained perform assembly and set up of the backstop. No one under the age of 18 should attempt assembly or set up of the unit, unless properly supervised.

To prevent normal wear and tear from shortening the life of the unit, preventative maintenance inspections and repairs should be performed at least once per year. If the units are subject to high or unusual usage, inspections should be scheduled to occur more frequently. If items are found to be nonconforming, replacements can be ordered from PSS or Gared Sports or one of our authorized dealers. When contacting PSS or Gared Sports, please have information regarding the dealer/installer who sold the unit, the name of the project, and any applicable warranty information.

Please note that PSS or Gared Sports assumes no responsibility for the building structure to support our products. We believe it is the responsibility of the building designers to determine the correct structure to support our products.

We will provide the project structural engineer with all the required weight and loading information for the specific project in order for them to calculate the appropriate structure.



Top Roll Divider Curtain



Read and understand the following warnings to prevent possible personal injury and potential damage to the equipment during assembly, setup, and operation.

WARNING

BEFORE OPERATING DIVIDER CURTAIN MAKE SURE THE AREA AROUND AND UNDER THE CURTAIN IS CLEAR OF OBSTRUCTIONS, EQUIPMENT, AND PEOPLE. MAKE CERTAIN NO PERSONS ARE NEAR THE CURTAIN DURING OPERATION. FAILURE TO FOLLOW THIS PROCEDURE COULD RESULT IN EQUIPMENT DAMAGE AND/OR SERIOUS PERSONAL INJURY

701955081

CAUTION

ONLY TRAINED AND AUTHORIZED PERSONNEL SHOULD OPERATE THIS EQUIPMENT. OPERATION BY UNTRAINED OR UNAUTHORIZED PERSONNEL MAY RESULT IN DAMAGE TO THE CURTAIN OR CURTAIN STRUCTURE AND/OR INJURY TO ANYONE NEAR THE CURTAIN.

ALWAYS MAKE SURE AREA AROUND AND BELOW THE CURTAIN IS CLEAR OF PERSONNEL AND OBSTACLES BEFORE OPERATING THE DEVICE.

NEVER STAND DIRECTLY UNDER THE CURTAIN DURING OPERATION.

OPERATOR MUST KEEP CURTAIN IN VIEW AT ALL TIMES DURING OPERATION.

KEY SWITCH OR CONTROL PAD MUST BE MOUNTED IN CLEAR VIEW OF THE CURTAIN.

NEVER LEAVE KEY IN KEY SWITCH UNATTENDED.

NEVER SWING OR SWAY THE CURTAIN.

NEVER HANG FROM SIDES OR BOTTOM BATTEN OF CURTAIN DURING OPERATION OR WHEN CURTAIN IS IN THE LOWERED POSITION.

CAUTION SHOULD BE EXERCISED AT ALL TIMES WHEN OPERATING THE CURTAIN.

ALWAYS FOLLOW PROPER SAFETY RULES.

Before proceeding with assembly, **read all instructions and assembly procedures**. Make sure all parts have been received and are not damaged. Verify all parts listed on packing list are present prior to installation. **Contact PSS or Gared customer service department for assistance with replacement of any parts missing or damaged.**



Top Roll Divider Curtain



Parts Checklist

(For Drop Mounted Carriers ONLY)

Item	Part number	Description	Qty	
			Single Motor	Dual Motor
1	101651293	SPACER, BEARING, TOP ROLL CURTAIN	4	4
2	101851298	BEARING, NEEDLE, TOP ROLL, 1/2" ID	4	4
3	111075278	SPRING PIN, 1/4 X 2	1	N/R
4	1195-01-00	KEYSWITCH ON COVER FOR 1194	1	1
5	1519-01-00	4" SQR COVER F/RECPT 1-19/32" DIA.	3	3
6	1771-27-08	1771 SUPPORT PIPE SLEEVE W/SET SCRE	3	3
7	1810-01-00	LOCKING RECEPTICAL - 4 BLADE	3	3
8	1811-01-00	LOCKING PLUG (MALE) - 4 BLADE	4	4
9	701705282	MOTOR SYNCHRONIZER FOR DUAL MOTOR(S)	N/R	1
11	705155043	CROWN ADAPTER - TUBULAR MOTOR	1	2
12	705154749	DRIVE ADAPTER - TUBULAR MOTOR	1	2
12a	705155044	IDLER ADAPTER	1	N/R
13	705155095	PLATE, END GUIDE	2	2
14	705155151	TUBULAR MOTOR - FOR TOP ROLL	1	2
15	705155216	WELDMENT, IDLER END GUIDE	1	N/R
16	502-5-18-20	BOLT, HEX HEAD MACH, 5/16" X 1-1/4"	2	N/R
17	541-5-18	NUT, HEX FULL FINISH 5/16"-18 ZINC	2	N/R
18	705155346	PLATE, MOTOR MOUNT	1	2
18a	111115416	COTTER PIN, 5/32 X 2"	1	2
19	506-5-4-20-10	SHOULDER BOLT, SCKT HD 5/16 X 5/8	2	4
20	111055275	U-BOLT, 3/8 X 2.375 X 4.0	See Packing List	
21	1900-04-00	TUBE,RND,1.9 OD X 0.083WALL HREW KK	See Packing List	
22	2375-04-00	TUBE,RND, 2.375 OD X 0.083 WALL KK	See Packing List	
23	501652091	WELDMENT, OFFSET DROP PIPE, 20"	See Packing List	
24	6050-11-00	3/16" X 3/16" DRIVE RIVET	See Packing List	
25	705154466	WELDMENT, TOP ROLLER CARRIER BRKT	See Packing List	
26	705154467	PLATE, BOTTOM ROLLER BRACKET	See Packing List	
27	705155415	PLATE, UPPER ROLLER SUPPORT	See Packing List	
28	705154626	4" ROLLER TUBE FOR TOP-ROLL CURTAIN	See Packing List	
29	705154714	SPLICE TUBE FOR TOP-ROLL CURTAIN	See Packing List	
30	705155122	ROLLER, 4040SD & 4040DD CURTAIN	See Packing List	
31	705155274	CARRIER HANGER BRACKET	See Packing List	
32	502-6-16-16	BOLT, HEX HEAD 3/8"-16 X 1"	See Packing List	
33	502-6-16-20	BOLT, HEX HEAD 3/8" X 1-1/4"	See Packing List	
34	502-8-13-48	BOLT, HEX HEAD 1/2"-13 X 3"	See Packing List	
35	545-6-16Z	NUT, NYLON LOCK 3/8"	See Packing List	
36	548-6-16	NUT, WHIZLOCK 3/8"	See Packing List	
37	548-8-13	NUT, HEX, SERRATED FLANGE 1/2"-13	See Packing List	
38	561-5	WASHER, FLAT 5/16" USS PLAIN	See Packing List	
39	561-6	WASHER, FLAT 3/8"	See Packing List	



Top Roll Divider Curtain



Parts Checklist

(For Direct Mounted Carriers ONLY)

Item	Part number	Description	Qty	
			Single Motor	Dual Motor
1	101651293	SPACER, BEARING, TOP ROLL CURTAIN	4	4
2	101851298	BEARING, NEEDLE, TOP ROLL, 1/2" ID	4	4
3	111075278	SPRING PIN, 1/4 X 2	1	N/R
4	1195-01-00	KEYSWITCH ON COVER FOR 1194	1	1
5	1519-01-00	4" SQR COVER F/RECPT 1-19/32" DIA.	3	3
6	1771-27-08	1771 SUPPORT PIPE SLEEVE W/SET SCRE	3	3
7	1810-01-00	LOCKING RECEPICAL - 4 BLADE	3	3
8	1811-01-00	LOCKING PLUG (MALE) - 4 BLADE	4	4
9	701705282	MOTOR SYNCHRONIZER FOR DUAL MOTOR(S)	N/R	1
11	705155043	CROWN ADAPTER - TUBULAR MOTOR	1	2
12	705154749	DRIVE ADAPTER - TUBULAR MOTOR	1	2
12a	705155044	IDLER ADAPTER	1	N/A
13	705155095	PLATE, END GUIDE	2	2
14	705155151	TUBULAR MOTOR - FOR TOP ROLL	1	2
15	705155216	WELDMENT, IDLER END GUIDE	1	N/R
16	502-5-18-20	BOLT, HEX HEAD MACH, 5/16" X 1-1/4"	2	N/R
17	541-5-18	NUT, HEX FULL FINISH 5/16"-18 ZINC	2	N/R
18	705155346	PLATE, MOTOR MOUNT	1	2
18a	111115416	COTTER PIN, 5/32 X 2"	1	2
19	506-5-4-20-10	SHOULDER BOLT, SCKT HD 5/16 X 5/8	2	4
21	1900-04-00	TUBE,RND,1.9 OD X 0.083WALL HREW KK	See Packing List	
22	2375-04-00	TUBE,RND, 2.375 OD X 0.083 WALL KK	See Packing List	
24	6050-11-00	3/16" X 3/16" DRIVE RIVET	See Packing List	
25	705154466	WELDMENT, TOP ROLLER CARRIER BRKT	See Packing List	
26	705154467	PLATE, BOTTOM ROLLER BRACKET	See Packing List	
27	705155415	PLATE, UPPER ROLLER SUPPORT	See Packing List	
28	705154626	4" ROLLER TUBE FOR TOP-ROLL CURTAIN	See Packing List	
29	705154714	SPLICE TUBE FOR TOP-ROLL CURTAIN	See Packing List	
30	705155122	ROLLER, 4040SD & 4040DD CURTAIN	See Packing List	
32	502-6-16-16	BOLT, HEX HEAD 3/8"-16 X 1"	See Packing List	
33	502-6-16-20	BOLT, HEX HEAD 3/8" X 1-1/4"	See Packing List	
34	502-8-13-48	BOLT, HEX HEAD 1/2"-13 X 3"	See Packing List	
35	545-6-16Z	NUT, NYLON LOCK 3/8"	See Packing List	
36	548-6-16	NUT, WHIZLOCK 3/8"	See Packing List	
37	548-8-13	NUT, HEX, SERRATED FLANGE 1/2"-13	See Packing List	
38	561-5	WASHER, FLAT 5/16" USS PLAIN	See Packing List	
39	561-6	WASHER, FLAT 3/8"	See Packing List	
40	705155274	CARRIER HANGER BRACKET	See Packing List	
41	705155345	DIRECT ATTACH BRACKET PLATE	See Packing List	
42	705155347	BEAM CLAMP PLATE	See Packing List	
43	502-8-13-56	BOLT, HEX HEAD 1/2"-13 X 3.5"	See Packing List	
44	561-8	WASHER, FLAT 1/2"	See Packing List	



Top Roll Divider Curtain



INSTALLATION

Tools Required:

Hammer

3/8" Hand Drill

Drill Bits – 3/16" and 1/2" with 3/8" Shank

3/8" Ratchet Wrench with 1/2" and 9/16" Sockets

1/2" Ratchet Wrench with 9/16", 11/16" and 3/4" Sockets

Wrenches – 1/2", 9/16", 11/16" and 3/4"

3/16" Allen Wrench

4" C-Clamps (2)

4' Level

File (half round)

25' Tape Measure

Cable Cutters

Utility Knives

Wire Stripper

Small Screwdriver

Ratcheting Pulleys (3-5 depending on length of curtain)

75' Ropes (3-5 depending on length of curtain)

100' 16-4 Wire (depending on length of curtain)

Wire Nuts

Duct Tape

Block of Wood (for tapping)

Broom

Shop Vac

IMPORTANT: A minimum of three people (more, depending on size of curtain) is recommended to be available to assist with the installation.

INSTALLATION INSTRUCTIONS

IMPORTANT: Locate, identify and count all parts before starting the installation to ensure that all are correct and correspond to the packing list/production drawings. Also review production drawings to ensure that building conditions have not changed since the initial field check. Verify overall height and width noted on drawings.

Before you begin:

Finished floor and curtain are easily damaged; therefore care should be taken to protect both. Make sure area is clean and free of debris. Sweep floor before laying protective covering. Protective covering should be at minimum the length and width of curtain. Have shop vacuum handy to sweep up any debris or metal shavings during installation.

Installing Overhead Structure

Because the overhead structure will vary per project, these guidelines are based on a typical job. Refer to the production drawings for specifics on your particular installation.

Two types of overhead structure are available for this divider curtain model. One is for attaching directly underneath the beam or truss and the second is for dropping the curtain below obstacles or in between joists. Check your installation prints included with the shipment and follow the procedures for the type of overhead indicated in those drawings.

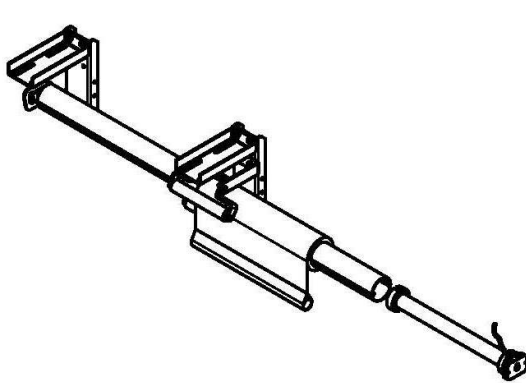

Direct Attach

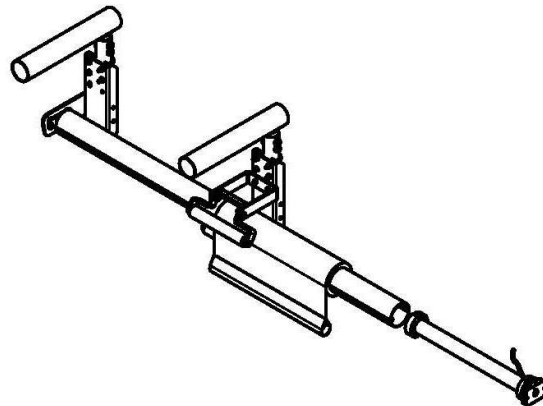

Drop Attach

Both types of overhead structure are used with the 4040SD (Single Motor) and 4040DD (Dual Motor) curtains.

The following pages provide instructions for both direct and drop attached overhead structures. Make sure to reference the correct parts list for the type of structure being installed.

Overhead Installation for Direct Mount Carriers

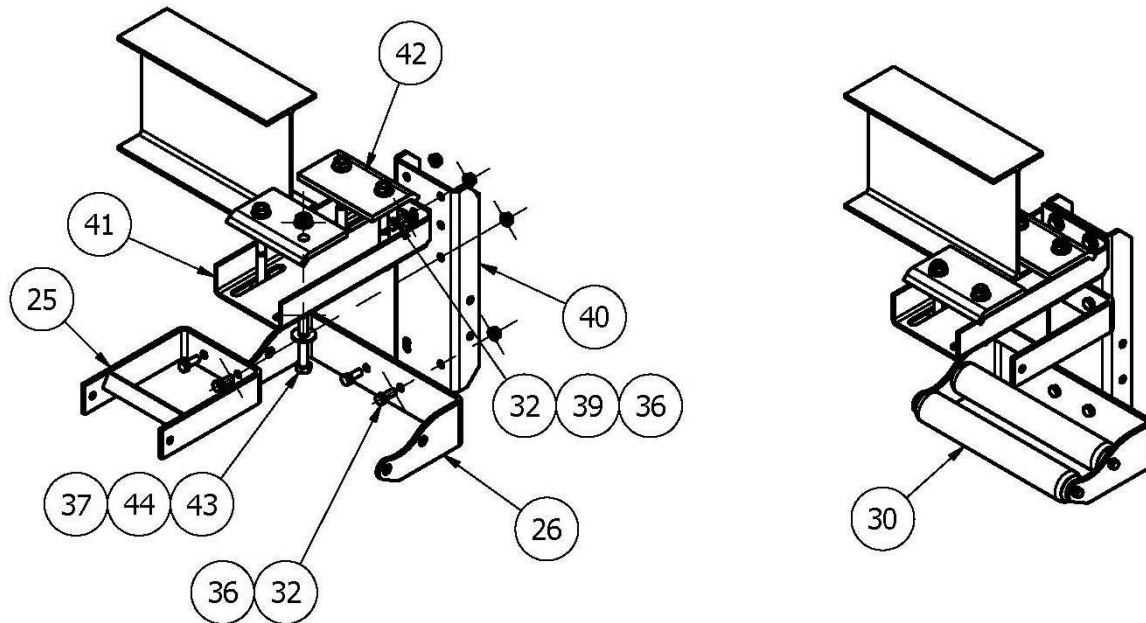

Figure 1

1. Using detail from production drawings, hang the Direct Attach Bracket plates (item 41) to the beam or truss using the Beam Clamp Plates (item 42) and the ½" x 3 ½" Hex Bolts (item 43), ½" Flat Washer (item 44), and ½" Whizlock Nut (item 37).

Refer to Figure 1 for the following steps

2. Starting at either end of overhead, attach Carrier Hanger Brackets (Item 40) to the Direct Attach Brackets using 3/8" x 1" Hex Bolts (item 32), 3/8" Flat Washer (item 39), and 3/8" Whizlock Nut (Item 36).

NOTE: Leave one direct attach bracket at each end open for the motor end and idler end bracket. These brackets will be installed later after the curtain is raised and the motor(s) and idlers have been installed.

3. Install the Bottom Roller Brackets (item 26) to the Carrier hanger Brackets using 3/8" x 1" Hex Bolts (item 32), 3/8" Flat Washer (item 39), and 3/8" Whizlock Nut (Item 36).
4. Install the Top Roller Carrier Brackets (item 25) to the Carrier hanger Brackets using 3/8" x 1" Hex Bolts (item 32), 3/8" Flat Washer (item 39), and 3/8" Whizlock Nut (Item 36).
5. Install the two Rollers (item 30) into the Bottom Roller Bracket. The roller shaft is spring loaded on one end. To install the roller, insert the fixed end into one side of the bracket, depress the shaft on the spring loaded end and slide the roller into position. The spring loaded shaft should snap into the opening in the bracket.

Important: After all carrier arm assemblies have been attached to the drop pipes, make sure the carrier arms are at the same level $\pm 1/16"$. A string line or laser may be used to check this alignment. It is critical at this point to make sure the carrier arms are in line, level, and perpendicular to the curtain.

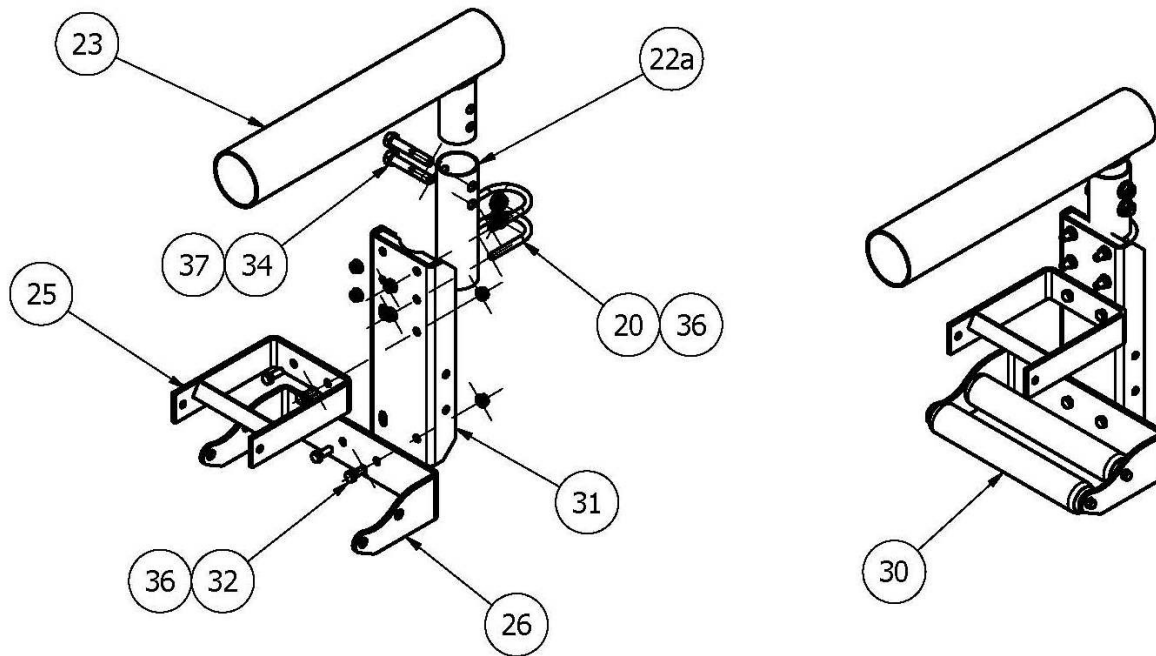

Figure 2

1. Using detail from production drawings, hang Offset Welded Drop (item 23) using standard beam clamps (not shown). Attach the 2-3/8" drop pipes (item 22a) using 1/2" x 3" bolts (item 34) and 1/2" Whizlock Nut (item 37). Make sure each drop pipe is plumb.

Refer to Figure 2 for the following steps

2. Starting at either end of overhead, attach Carrier Hanger Brackets (Item 31) to the Drop Pipes using 3/8" x 2 3/8 x 4" U-Bolts (item 20), 3/8" and 3/8" Whizlock Nut (Item 36).

NOTE: Leave one drop at each end open for the motor end and idler end bracket. These drops will be installed later after the curtain is raised and the motor(s) and idlers have been installed.

3. Install the Bottom Roller Brackets (item 26) to the Carrier hanger Brackets using 3/8" x 1" Hex Bolts (item 32), 3/8" Flat Washer (item 39), and 3/8" Whizlock Nut (Item 36).
4. Install the Top Roller Carrier Brackets (item 25) to the Carrier hanger Brackets using 3/8" x 1" Hex Bolts (item 32), 3/8" Flat Washer (item 39), and 3/8" Whizlock Nut (Item 36).
5. Install the two Rollers (item 30) into the Bottom Roller Bracket. The roller shaft is spring loaded on one end. To install the roller, insert the fixed end into one side of the bracket, depress the shaft on the spring loaded end and slide the roller into position. The spring loaded shaft should snap into the opening in the bracket.

Important: After all carrier arm assemblies have been attached to the drop pipes, make sure the carrier arms are at the same level $\pm 1/16"$. A string line or laser may be used to check this alignment. It is critical at this point to make sure the carrier arms are in line, level, and perpendicular to the curtain.

6. After all carrier brackets are installed, adjust them for level, plumb, and alignment. One recommended approach for level and alignment is to start at one end and adjust the carrier roller

to level, adjust the height to the desired height (check installation drawing for correct height), and adjust the roller to the correct alignment of the curtain vinyl. Tighten all bolts on the carrier assembly. Using one 20' piece of the 4" aluminum roller tube (item 28), lay the roller tube in the end carrier and the second carrier. Now using the tube and a level as a guide, make the same adjustments on the second carrier and tighten all bolts. Continue this process with the drive tube until all carriers have been adjusted for level and alignment.

Note: Refer to “Raising Curtain to Overhead” section for additional pieces of equipment that can be set up at this point in the installation for later use.

Attaching Curtain to Drive Tube

Make sure floor area is clean and free of debris. Sweep if necessary, and lay protective covering before unfolding curtain vinyl.

1. Lay vinyl out, positioning below the overhead support if possible.
2. The curtain vinyl has been manufactured to include a nylon cord sewn into the upper pocket of the vinyl. This nylon cord is used instead of aircraft cable supplied on older curtains. There is no preparation required for the top of the vinyl.
3. Lay drive tube along top edge of curtain. Locate the lengths of drive tube according to the installation print provided with the shipment. (Depending on the overhead structure, drive tube may be longer on one or both ends, and center splice may not fall at center of curtain.)
4. Install the splices at each joint of the drive tube. See figure 3 next page.

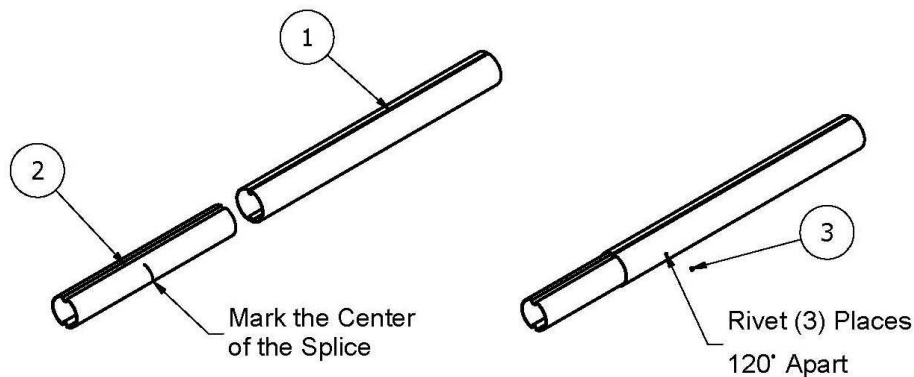

Figure 3

Refer to Figure 3 for the following step



Top Roll Divider Curtain



5. Mark center of splice and insert into drive tube. Using a 3/16" drill bit, drill three equally spaced holes through drive tube and splice. Insert rivets and tap into place. To avoid damage to vinyl or mesh, be sure to sweep up all metal shavings left from drilling.
6. Continue process until drive tube has been completely installed on vinyl.
7. Slide the vinyl onto one end of the assembled drive tube. A pull loop has been provided on one end of the vinyl to allow for easier insertion into the drive tube. Align the vinyl cord and sewn top pocket into the groove of the drive tube and pull the vinyl along the length of the drive tube. Continue to pull the vinyl until the vinyl is centered on the length of the drive tube.
8. Once the curtain vinyl is installed onto the full length of the drive tube and centered on the drive tube, attach a band clamp to the tail of the vinyl on the opposite end from the pull loop. Securely tighten this clamp to hold the vinyl in position on the tube.
9. Pull the pull loop as tight as possible to stretch the vinyl along the drive tube and attach a second band clamp to the tail of the vinyl at the pull loop end. Tighten the band clamp securely. The curtain vinyl is now securely attached to the drive tube to prevent movement of the vinyl during operation.
10. The pull loop can now be cut off if desired.

Installing Bottom Batten

Bottom Batten consists of three or more pieces (depending on size of curtain) of 1.9" O.D. pipe. End batten tubes are drilled on one side only.

1. Remove acorn nut and bolt from bottom curtain pocket.
2. Slide non-drilled end piece of bottom batten pipe into curtain pocket, leaving 1' of pipe exposed. Slide first splice into pipe end, aligning pre-drilled holes, and tighten setscrews.
3. Slide next piece of pipe onto splice, and continue above procedure until bottom batten is complete.
4. Replace acorn nut and bolt, and tighten securely.

Curtain is now read to be raised to the overhead.

Drive motor(s) may be installed prior to raising curtain or after curtain has been raised and secured in the overhead carrier assemblies. Refer to motor installation section for further instructions.

WARNING

If motor(s) are to be installed prior to raising curtain to overhead structure, refer to installing motor section before proceeding. Motor limit switches must be pre adjusted prior to inserting the motor(s) into the drive tube. Failure to follow the pre-adjustment procedure could result in damage to the motor limit switches while attempting to set the final positions during operation.

Raising Curtain to Overhead

The following methods of raising the curtain are merely suggestions, as each installation will vary depending on curtain size and facility. Additional equipment needed to raise curtain is not supplied, and is listed under "optional" on the Tool List. We recommend three or more people be available to assist in raising the curtain. If your installation is particularly difficult due to facility conditions, please contact Performance Sports for additional information.

Method #1 -

Make sure curtain is aligned with overhead drops and evenly spaced between end brackets. For convenience, steps 1 and 2 can be done while installing curtain overhead.

1. Evenly space and securely attach standard or ratchet pulleys above overhead using chain or rope.
2. Thread rope through pulleys allowing enough length for rope to dangle on floor.
3. On top side of drive tube, drill cross-holes (3/8" or 1/2" depending on rope size), spacing each hole to match pulleys attached to overhead. Make sure to drill beyond 26" from the end of the drive tube to have clearance for the end of motor when installed.
4. Sweep up all metal shavings.
5. Insert ends of ropes through holes in drive tube, and tie securely.
6. Leaving curtain unrolled, slowly and evenly begin to raise curtain.
7. Once curtain has reached overhead assemblies, make sure ratchet pulleys are secure, or if using standard pulleys, rope is securely tied.

Refer to Figure 6 for the following steps

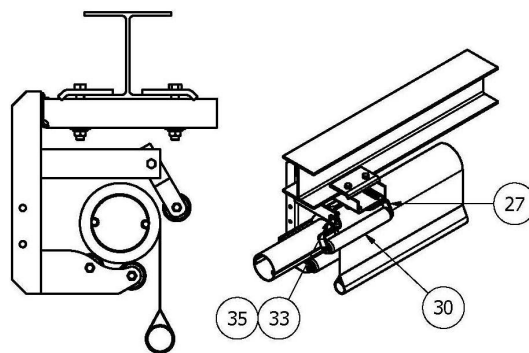

Figure 6

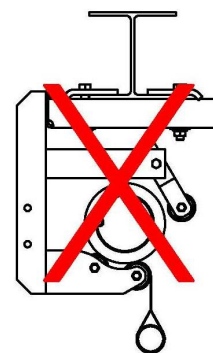

Figure 7

8. Using lift or scaffold and starting on either end, manually lift and place the tube onto Lower Carrier Support Rollers.
9. Install the Rollers (item 30) into the Top Roller Bracket (Item 27). The roller shaft is spring loaded on one end. To install the roller, insert the fixed end into one side of the bracket, depress the shaft on the spring loaded end and slide the roller into position. The spring loaded shaft should snap into the opening in the bracket. Attach Upper Support Arm (Item 27) with two 3/8"x 1 1/4" Hex Bolts (item 33) and 3/8" Nylon Lock Nuts (item 35). Do not over tighten the nuts. Make sure the upper roller arm is free to move after installation.

Important: Make sure vinyl will roll over the top of the drive tube as shown in Figure 6 and not under the drive tube as shown in Figure 7.

10. Repeat steps 8 and 9 until all Support Arm Assemblies have been installed, and the curtain is secure.
11. If motor(s) have not been installed, insert at this time, using procedure outlined in Motor Installation section.

Method #2

1. Using small, 500 lb. capacity electric hoists, secure to hoists above overhead.
2. Attach pulleys using rope or chain, and thread rope through, allowing rope to dangle to ground.
3. Follow steps in Method #1, beginning with step #3.

Method #3

1. If two or more lifts are available, roll curtain up (make sure to roll in the correct direction) and carefully lay across lifts, making sure to distribute weight evenly. Secure curtain and slowly raise lifts in an even fashion until desired height is achieved.
2. Following instructions above, beginning with step #8.

Installing Motor(s)

When the application requires the Dual Motor drive arrangement (refer to your drawings included with the shipment) two motor(s) will be installed. When the application requires a Single Motor, only one motor will be installed.

IMPORTANT NOTE:

The drive motor(s) are shipped from the factory with the initial position set in the middle of the limit switch range with approximately 4 motor turns either direction. There are approximately 14 motor turns either direction available between the maximum upper and maximum lower limit positions. Installing motor(s) without pre-adjusting limits of the motor results in only 14 total turns and that may not be enough to allow for total vinyl travel and may result in driving the limit adjuster off the cam. Always preset the motor(s) per the following instructions before installing in the drive tube of the curtain to insure the quickest setup.

WARNING

Failure to follow the pre-adjustment procedure could result in damage to the motor limit switches while attempting to set the final positions during operation.

Pre-adjusting the motor travel and limits

Single Motor Drive

1. Remove motor from box and position it next to the drive tube as it will be installed. Refer to the Motor Illustration for the next steps.

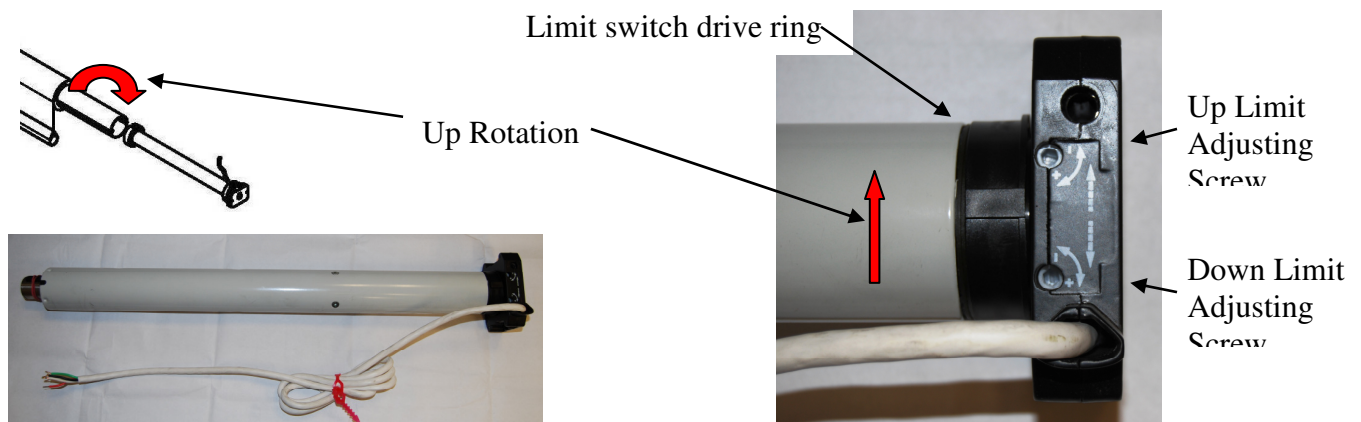

Motor Illustration

Note: The number of turns on the drive ring can vary as much as +/- 2 turns. It is possible you might hear the limit click before 4 turns or you may reach 6 turns without hearing the limit. If you turn too

far, the drive ring will begin turning hard. DO NOT FORCE ROTATION. Back the ring up until you hear the limit switch click.

2. Determine the direction of rotation for the curtain (refer to Step 4 of these instructions) and mark the rotation on the top of the motor with a felt pen. The up limit switch is always on the arrow side of the mark while the down limit switch is always at the tail of the mark.
3. Rotate the limit drive ring by hand in the down direction until you hear the limit switch click (about 4 to 6 turns). Rotate the limit drive ring back ½ turn making sure you hear the limit switch click.
4. The motor is now ready to be installed in the drive tube.

Dual Motor Drive

1. Remove motors from boxes and position them next to the drive tube as they will be installed. Mark one motor as #1 and the other as #2. Motor #1 will be set as master control of the limits. Refer to the Motor Illustration for the next steps.
2. On both motors, rotate the limit drive ring by hand in the “down” direction until you hear the limit switch click (about 4 to 6 turns).
 - a. Rotate the limit drive ring back ½ turn on Motor #1, making sure you hear the limit switch click.
 - b. Rotate the limit drive ring back 2 turns on Motor #2, making sure you hear the limit switch click.
3. On Motor #1 (controlling motor), rotate the up limit switch adjustment in the “+” direction approximately 30 turns. On Motor #2 (non-controlling motor), rotate the up limit switch adjustment in the “+” direction approximately 70 turns.
4. The motors are now ready to be installed in the drive tube.

Pre-assemble motor parts according to instructions below.

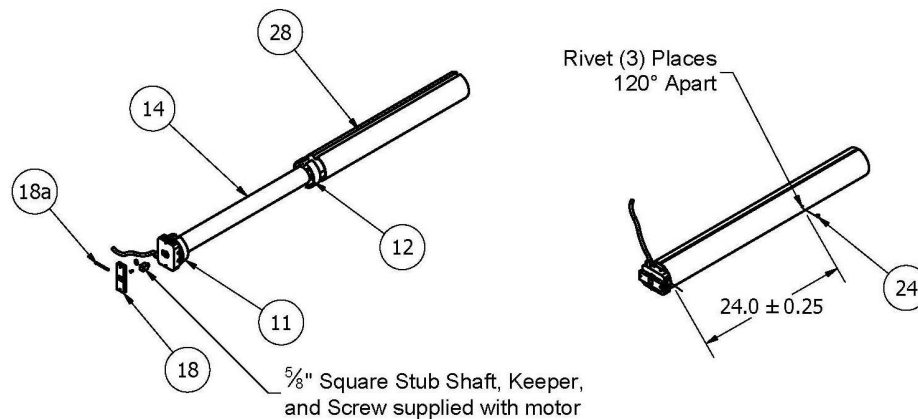

Figure 4

Refer to Figure 4 for the following steps

1. Install Crown (Item 11) and Drive (Item 12) onto motor(s). When the aluminum drive adapter is installed on the motor, install the snap ring on the motor shaft. The snap ring is supplied as part of the motor kit and can be found packed in the motor box.
2. Install the 5/8" square stub shaft in the end of the motor and secure with the keeper and flat head screw. The 5/8" square stub shaft, keeper, and flat head screw are supplied as part of the motor kit and can be found packed in the motor box.
3. Insert a motor into each end of drive tube until flush (for Dual motor drive applications) by aligning grooves on drive with channels in drive tube. Or insert a motor into one end of drive tube until flush (for Single motor drive applications) by aligning grooves on drive with channels in drive tube.
4. Secure motor(s) in drive tube by riveting the drive adapter of the motor to the drive tube. Using a 3/16" drill bit, drill three equally spaced holes through drive tube and drive adapter 24" \pm 1/4" from the end of the drive tube. Insert rivets and tap into place. To avoid damage to vinyl or mesh, be sure to sweep up all metal shavings left from drilling.

Installing idler

(For Single Motor installations ONLY)

When the application requires a Single Motor, an idler will be in the opposite end of the drive tube from the motor.

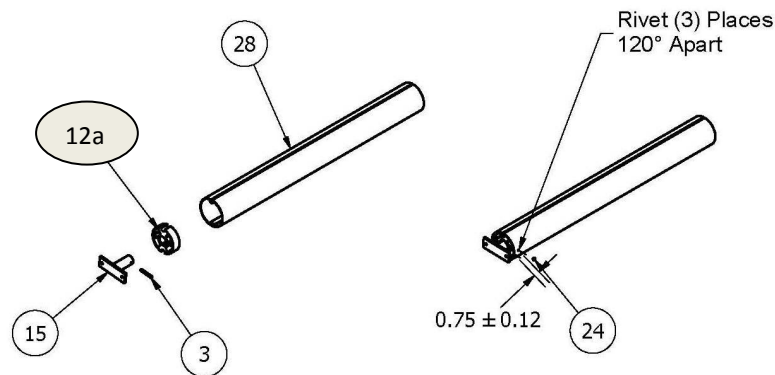

Figure 5

1. Install the plastic drive adapter (item 12a) onto the idler shaft (item 15).
2. Insert the spring pin (item 3) into the hole in the idler shaft to retain the drive crown.
3. Insert the assembly into the drive tube (item 28) until the drive crown is about 1/4" from the end of the drive tube.
4. Secure idler in drive tube by riveting the drive adapter of the idler to the drive tube. Using a 3/16" drill bit, drill three equally spaced holes through drive tube and drive adapter 3/4" \pm 1/8" from the end of the drive tube. Insert rivets and tap into place. To avoid damage to vinyl or mesh, be sure to sweep up all metal shavings left from drilling.

Installing Idler End Brackets and Motor End Brackets

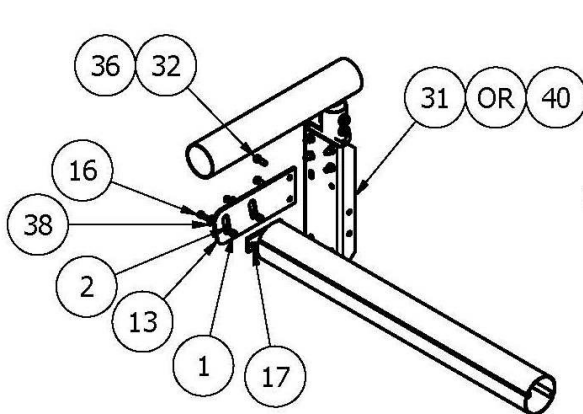

Figure 8

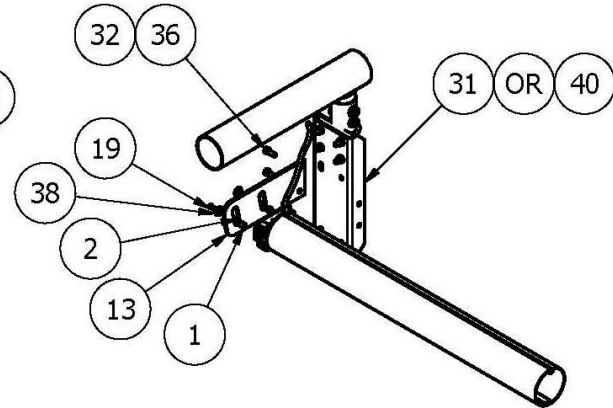

Figure 9

Refer to Figure 8 for installing Idler End Brackets on Single Motor Applications

1. Attach Carrier Hanger Bracket (Item 31 or 40) to Direct Attach Bracket or Drop Pipe as installed in the Installing Overhead Structure section. Attach End Guide Plate (item 13) to the Carrier Hanger Bracket using 3/8" x 1" Hex Bolts (item 32) and 3/8" Whizlock Nuts (item 36). Install a 5/16" Flat Washer (item 38) onto the 5/16" x 1 1/4" Hex Bolt (item 16). Insert bolt with washer through bearing spacer (Item 1). Add a small amount of grease to needle bearing (Item 2) and slide bearing onto spacer making sure needle bearing is free to rotate on spacer. Insert the bolt and bearing assembly through the slot in the end plate and tighten into the threaded portion of the Idler Guide Plate. Tighten securely and add a 5/16" Nut (item 17) to lock the bolt.
2. Check for freedom of movement of motor bracket in the end plate slots.

Refer to Figure 9 for installing Idler motor Brackets on Single Motor & Dual Motor Applications

3. Attach Carrier Hanger Bracket (Item 31 or 40) to Direct Attach Bracket or Drop Pipe as installed in the Installing Overhead Structure section. Attach End Guide Plate (item 13) to the Carrier Hanger Bracket using 3/8" x 1" Hex Bolts (item 32) and 3/8" Whizlock Nuts (item 36). Install a 5/16" Flat Washer (item 38) onto the Socket Head Shoulder Bolt (item 19). Insert bolt with washer through bearing spacer (Item 1). Add a small amount of grease to needle bearing (Item 2) and slide bearing onto spacer making sure needle bearing is free to rotate on spacer. Insert the bolt and bearing assembly through the slot in the end plate and into the holes in the motor mounting plate. Tighten the shoulder bolt securely.
4. Check for freedom of movement of motor bracket in the end plate slots.
5. Check the Level of the Drive Tube using laser or level. Tube must be completely level for curtain to roll evenly.

Temporary Wiring Motors for the Dual Motor Installation

Refer to wiring diagram (Page 18) for hardwire or temporary wiring instructions of the Dual Motor Drive.



Top Roll Divider Curtain



1. For temporary wiring, using 16.4 wire (not provided), divide wire evenly in length between ends of curtain.
2. Wire motor wires and 16.4 wire together (green to green, red to red, etc.) and hold with wire nuts.
3. Draping 16.4 wire to floor, wire ends into Synchronizer Unit according to wiring diagram, and wire to power source.
4. Wire key switch to terminal block on Synchronizer Unit with 4' – 5' of temporary wire.
5. Plug power source into 120V outlet.

WARNING: Box is now HOT. Use caution to avoid risk of electrical shock. As a safety precaution, leave Synchronizer Unit on floor and handle only key switch when operating curtain.

IMPORTANT NOTE: Make sure vinyl rolls over the top of the tube when raising the curtain. DO NOT allow vinyl to roll under the tube.

Temporary Wiring Motor for the Single Motor Installation

Refer to wiring diagram (Page 17) for hardwire or temporary wiring instructions of the Single Motor Drive.

1. Attach the 4 prong locking plug (item 8) to the motor power cable.
2. Connect the test cord (not supplied) to the motor plug. The test cord is normally used to set the limit switches on all backstop hoists.
3. Plug the test cord into 120V outlet.

Step 13 - Setting Motor Limits

Note: The motor(s) operating the curtain have an automatic thermal shut off function after 6 minutes of continuous running to prevent overheating and damaging of fabric. Cool down takes 15-20 minutes depending on fabric wrap and ambient temperature. The motor(s) will not run during this time and will automatically reset themselves.

Operate the adjusting screw according to the direction of travel arrows.

Turn the limit switch adjusting screws as follows:

- **Minus (-)** = shorter travel (less up travel on the UP limit, less down travel on the DOWN limit)
- **Plus (+)** = longer travel (more up travel on the UP limit, more down travel on the DOWN limit)

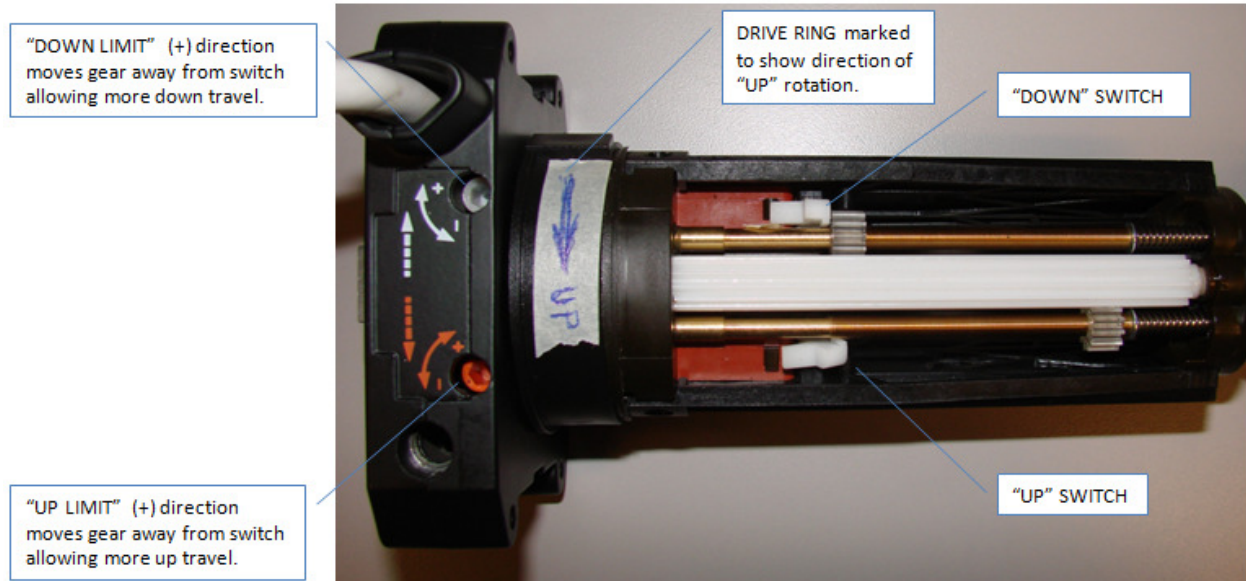

Cutaway view showing micro switches.

Example show drive ring marked for clockwise, “UP” rotation. Switches will be reversed for counter clockwise, “UP” rotation.

(For Single Motor Installation)

Note: Use the temporary wiring for Single Motor Installation

When starting with the vinyl down (unwrapped), adjust the down limit first then adjust the up limit.

Adjustment of the “Down” direction

1. Raise the vinyl about 6” before proceeding.
2. Allow the motor to run in the “down” direction.
 - a. If the motor stops before reaching the desired down position, go to step #3.
 - b. If the motor does not stop before reaching the full lowered position, stop motor travel manually and raise the curtain to a position about 6” above desired height. Turn the “down” adjusting screw in the “-“ (minus) direction until the micro switch click is heard.
3. Hold the “down” button on the test cable on. At the same time, turn the “down” adjusting screw in the “+“ (plus) direction until the desired end position is reached. Each turn of the adjusting screw will move the bottom edge of the curtain approximately 3” or (9) turns of the adjusting screw equals (1) motor revolution).

Adjustment of the “Up” direction

1. Allow the motor to run in the “up” direction.
 - a. If the motor stops before reaching the desired top position, go to step #2.
 - b. If the motor does not stop before reaching the fully raised position, stop motor travel and lower curtain to a position about 12” below desired height. Turn the “up” adjusting screw in the “-“ (minus) direction until the micro switch click is heard.



Top Roll Divider Curtain



2. Hold the “up” button on the test cable on. At the same time, turn the “up” adjusting screw in the “+” (plus) direction until the desired end position is reached. Each turn of the adjusting screw will move the bottom edge of the curtain approximately 1 ½” or (9) turns of the adjusting screw equals (1) motor revolution).

(For Dual Motor Installation ONLY)

Note: Use the temporary wiring for Dual Motor Installation

Set the limits on Motor #1 (controlling motor) first.

1. Follow the procedure for a Single Motor drive with one exception. The motor must be reversed a few inches each time the limit has been reached to reset the synchronizer control. Each turn of the adjusting screw will move the bottom edge of the curtain approximately 3”.

Setting the limits of Motor #2

Setting the limits on Motor #2 will act as a backup to the Motor #1 controlling limits.

1. Raise the curtain until it stops (the Motor #1 limit will stop the curtain)
2. Turn the “up” adjusting screw in the “-” (minus) direction until the micro switch clicks. Turn in the “+” direction ½ turn.
3. Lower the curtain until it stops (the Motor #1 limit will stop the curtain)
4. Turn the “down” adjusting screw in the “-” (minus) direction until the micro switch clicks. Turn in the “+” direction ½ turn.

Step 14 - Checking the limit positions

1. Deploy and retract the curtain 1 or 2 more times to ensure that the limits are set correctly and that the motor(s) are wired correctly.

Keep in mind that for every second of run time on the motor(s) they should have a second of rest after reaching the set limit. (Example: If it takes 3 minutes to deploy the divider the motor should be at rest for 3 minutes)

2. Determine whether to leave curtain in up or down position. (Leaving curtain in down position will help remove wrinkles from vinyl.)

Disconnect temporary wiring, and leave synchronizer unit and key switch with Electrician or General Contractor. Make sure Facility Electrician or Facility Manager has a copy of the wiring schematic that was furnished with the installation drawings.



Top Roll Divider Curtain



Permanent Wiring Motor(s) for Installation

A qualified electrician should complete all permanent wiring.

The permanent wiring should be installed in accordance with the electrical schematic furnished with the installation drawings at time of delivery of the product.

On dual motor installations, the key switch is powered by 5vdc from the synchronizer control. Use a shielded wire and do not run with or near other AC power wires, lights, or HVAC devices.

Notes to Electrician

Make sure the wiring from the synchronizer box to each motor is connected as shown on the wiring diagram. Dual motor curtains must run in opposite directions to function properly. The motor rotation has been reversed inside the synchronizer control. DO NOT REVERSE AT THE MOTOR. The limit switches should already be set by the installer, but if not refer to the “Setting Motor Limits” section.

Make sure vinyl rolls over the top of the tube when raising the curtain. DO NOT allow vinyl to roll under the tube. Refer to Figures 6 and 7 for proper direction of roll.

Electrical Requirements

115V ELECTRICAL SPECIFICATIONS:

- DEDICATED 15A CIRCUIT BREAKER (by others)
- MOTOR: 115VAC +/- 10%, 1 PH, 60 HZ, 3.4A (6.8A dual motor)

SYNCHRONIZER BOX:

7 1/2" L x 4" W x 3" DEEP

MINIMUM KEY SWITCH BOX SIZE:

3" TALL x 2 1/4" W x 2 1/2" DEEP

Copper wire, 3% voltage drop

3.4 amps, 115 volt, 1 phase, 60 hz

Maximum Wire Length (ft)	Wire Size AWG
167	14
265	12
421	10
670	8
1,065	6

Copper wire, 3% voltage drop

6.8 amps, 115 volt, 1 phase, 60 hz

Maximum Wire Length (ft)	Wire Size AWG
83	14
133	12
211	10
335	8
533	6

220V ELECTRICAL SPECIFICATIONS:

- DEDICATED 10A CIRCUIT BREAKER (by others)
- MOTOR: 220VAC +/- 10%, 1 PH, 50 HZ, 1.9 A (3.8 A dual motor)

SYNCHRONIZER BOX:

7 1/2" L x 4" W x 3" DEEP

MINIMUM KEY SWITCH BOX SIZE:

3" TALL x 2 1/4" W x 2 1/2" DEEP

Copper wire, 3% voltage drop

1.9 amps, 220 volt, 1 phase, 50 hz

Maximum Wire Length ft [m]	Wire Size AWG	Wire Size mm2
359 [109 m]	16	1.3
571 [174 m]	14	2.1
907 [277 m]	12	3.3

Copper wire, 3% voltage drop

3.8 amps, 220 volt, 1 phase, 50 hz

Maximum Wire Length ft [m]	Wire Size AWG	Wire Size mm2
179 [55 m]	16	1.3
285 [87 m]	14	2.1
454 [138 m]	12	3.3

120 V Wiring Diagram (Single Motor Installation ONLY)

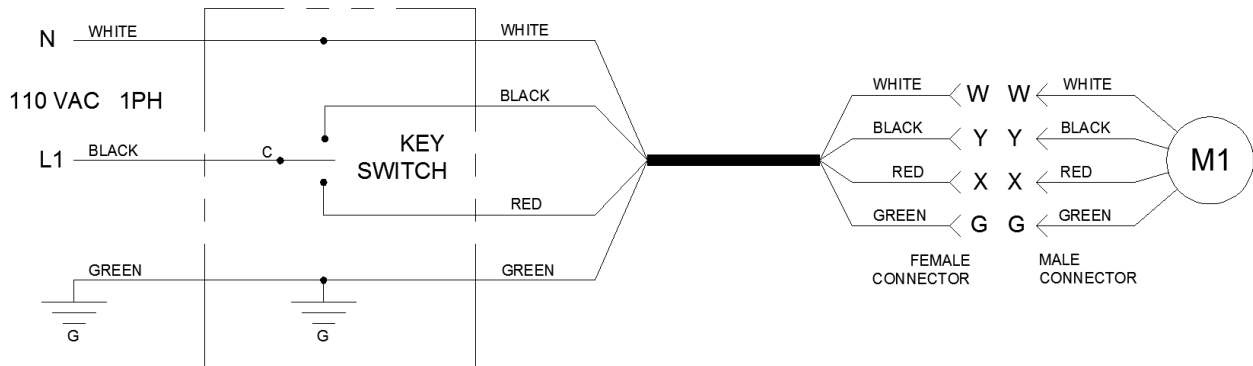

220 V Wiring Diagram (Single Motor Installation ONLY)

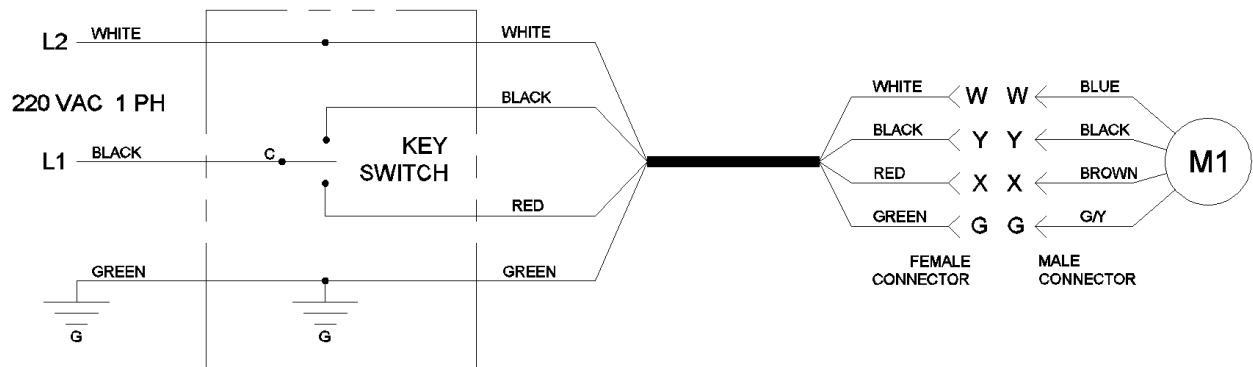

120 V Wiring Diagram w/ 701705282 Controller (Dual Motor Installation ONLY)

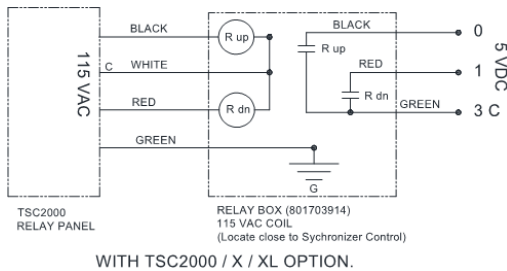
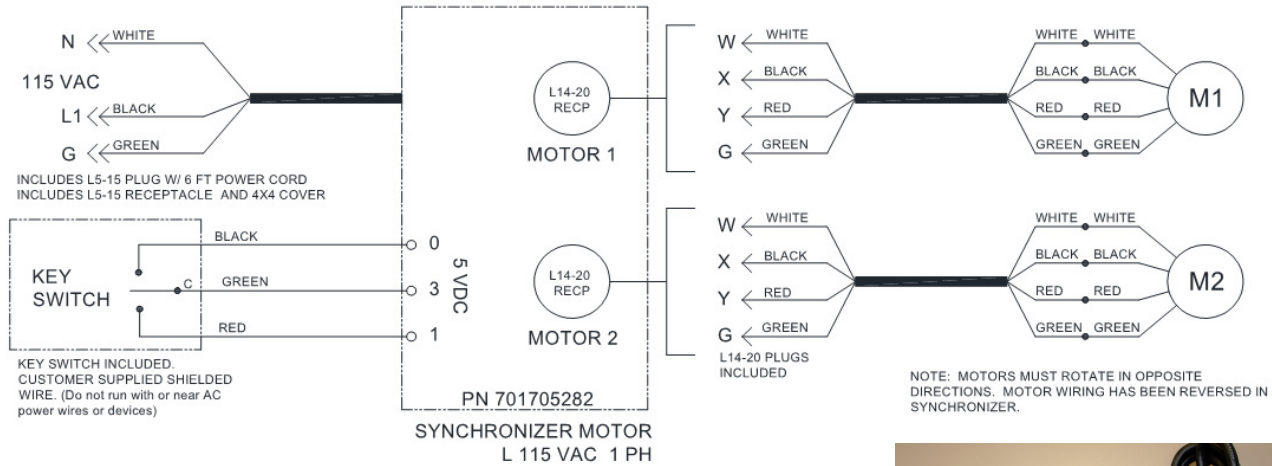

220 V Wiring Diagram w/ 701705621 Controller (Dual Motor Installation ONLY)

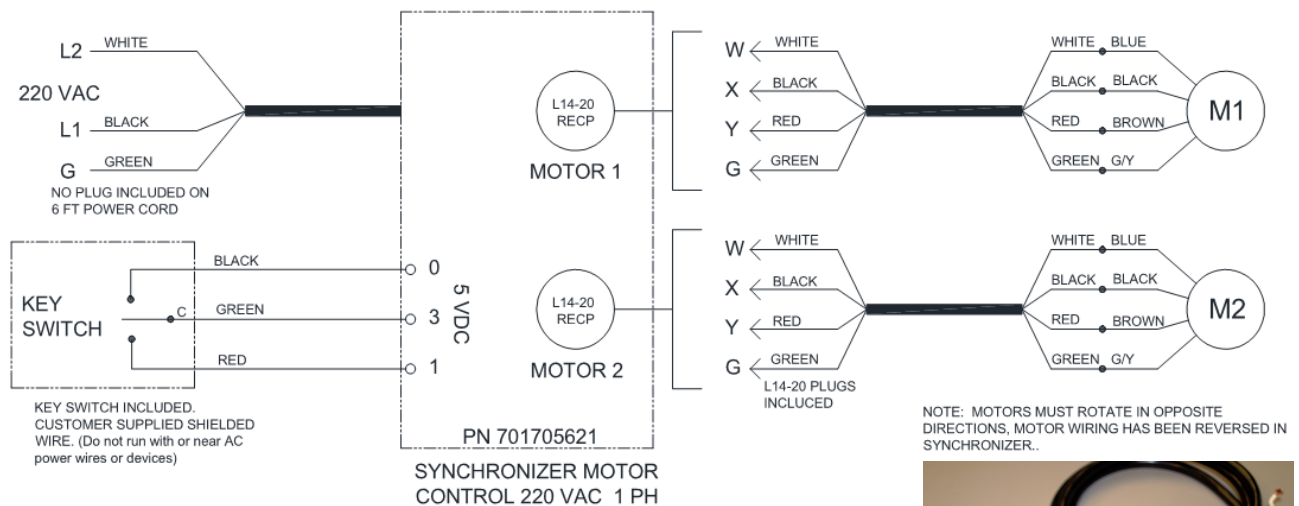

120 V Wiring Diagram w/ 4041-27-00 Controller (Dual Motor Installation ONLY)

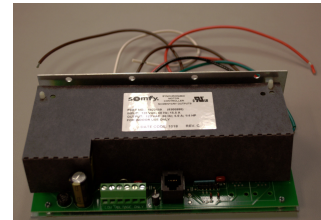
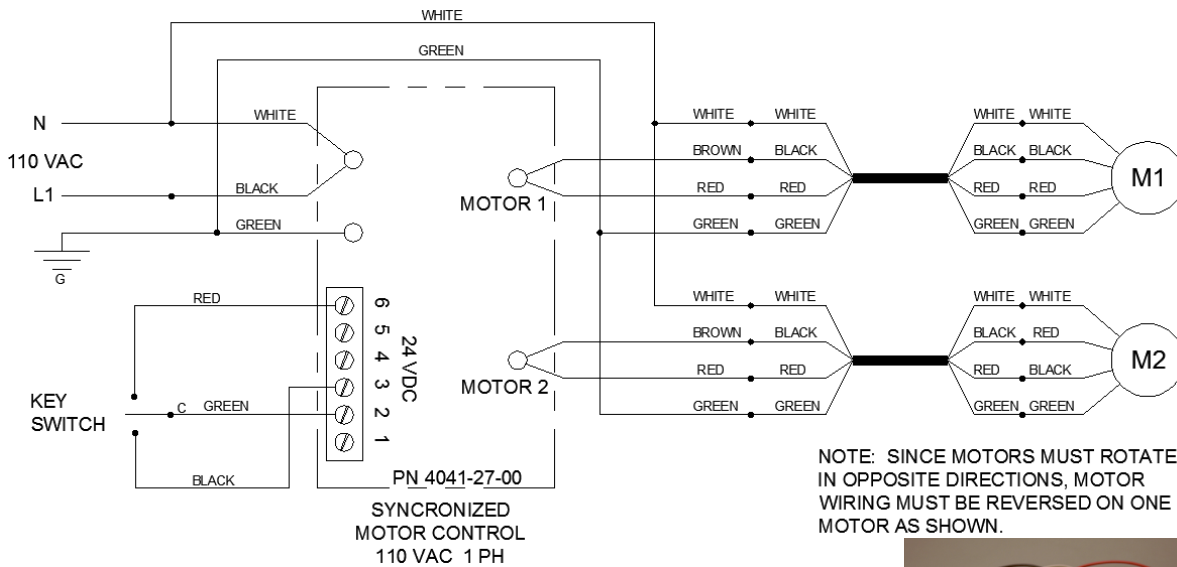

220 V Wiring Diagram w/ 4041-27-01 Controller (Dual Motor Installation ONLY)

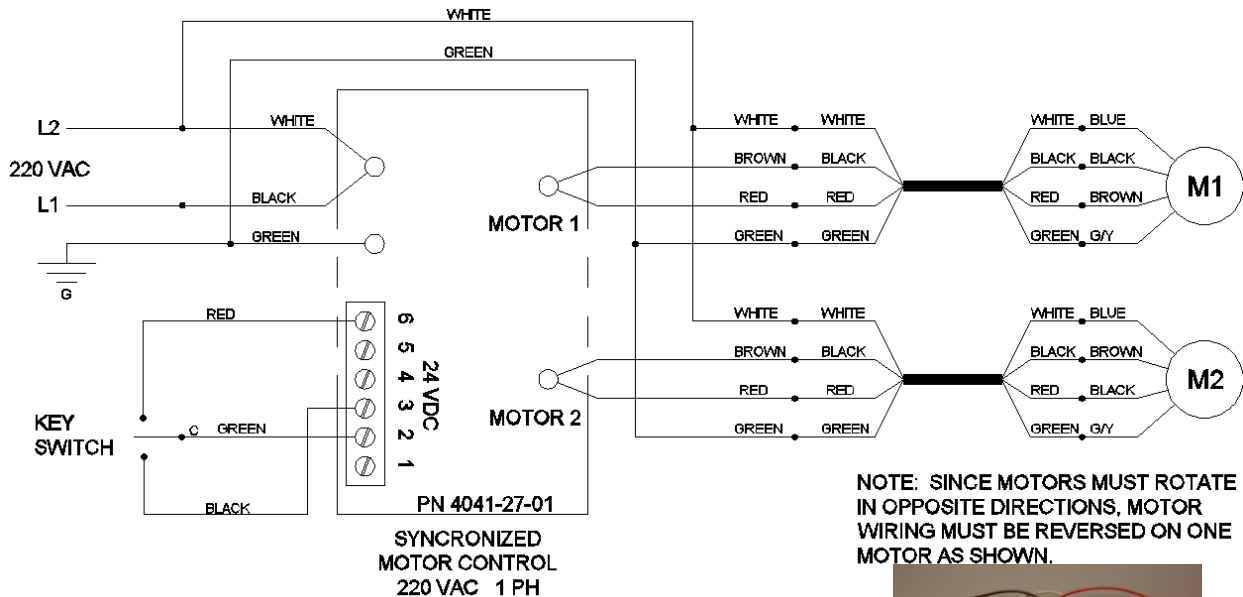



Top Roll Divider Curtain



PLEASE DO NOT ATTEMPT TO OPERATE THIS EQUIPMENT BEFORE READING THE FOLLOWING INFORMATION!!!

MODEL #4040 TOP ROLL DIVIDER CURTAIN

PRODUCT OVERVIEW

The following information is designed to assist you with the operation and maintenance of your Model #4040 Top Roll Divider Curtain. We recommend that you carefully read this literature to become familiar with your new divider curtain, then develop an operation and maintenance program for the designated operator of the curtain.

It is very important that this divider curtain be operated by **AUTHORIZED PERSONNEL ONLY**. This curtain has been manufactured with safety in mind, but even the safest equipment can be damaged or cause damage to a person or persons when operated by unauthorized or untrained users.

- Tremendous force is created when this curtain is in motion.
- Only authorized personnel may operate curtain.
- Care must be taken to make sure the curtain and areas above and below the curtain are free and clear of any obstructions.
- Do not stand directly below the curtain when raising or lowering.
- Never swing or sway curtain.
- Structure and motor units were designed to lift the weight of the curtain only.
- Never hang from sides or bottom of curtain during operation or when curtain is in the lowered position.
- Never attach or place foreign objects on the curtain.

OPERATION OF THE MODEL #4040 TOP ROLL DIVIDER CURTAIN:

1. The key switch used to control the up/down motion of this curtain must be flush mounted on a wall that gives the operator a clear and full view of the curtain. Never operate the curtain if conditions do not allow for a clear and full view of the curtain.
2. The curtain may be raised or lowered by turning the key to the appropriate “Up” or “Down” position, as indicated on the switch cover plate.
3. The key that operates the curtain must remain in the possession of the authorized operator.

NEVER LEAVE THE KEY UNATTENDED IN THE KEY SWITCH



Top Roll Divider Curtain



4. The motor(s) that control the movement of the curtain have been programmed to stop the curtain at a predetermined “up” and “down” position. Should the curtain stop before it reaches these predetermined positions the motor(s) may have over heated and need to cool off. Allow the divider to rest for approximately 20 minutes and try to run again. If the divider still does not run contact your dealer or installation company immediately.

This divider curtain should be lowered to its full down position periodically to allow the vinyl to naturally stretch and remove any minor wrinkles caused from normal operation. It is recommended that the divider curtain be extended to the full down position and left in the down position for a period of 24 to 48 hours at least twice monthly.

While it is possible to lower or raise the curtain partially during normal operation, it is not recommended. Continued raising or lowering to a partial position can create wrinkles in the fabric and possible damage to the vinyl. Raising or lowering the divider curtain to a partial position should only be done when maintenance is required on the divider curtain drive components or structure.

This divider curtain has been custom manufactured according to the Owner's/Architect's specifications. When operated and maintained with proper care, this curtain should provide years of safe, trouble-free service.



Top Roll Divider Curtain



MAINTENANCE INFORMATION – PLEASE RETAIN FOR FUTURE REFERENCE!!!

MODEL #4040 TOP ROLL DIVIDER CURTAIN

MAINTENANCE OVERVIEW

!!!ALWAYS DISCONNECT POWER SOURCE BEFORE PERFORMING ANY MAINTENANCE CHECK OR OPERATION ON THIS EQUIPMENT!!!

STRUCTURE:

We recommend a yearly inspection (or more frequently depending on usage) of the nuts and bolts, checking for tightness.

MOTOR(S):

The tubular motor(s) that operate your divider curtain do not require any maintenance. We do recommend however, that the limit switches be checked on a regular basis to ensure the settings are accurate.

CURTAIN VINYL:

The curtain vinyl should be checked on a regular basis for rips or tears. Should the vinyl become ripped or torn, it must be repaired or replaced. Contact your dealer or installation company for information on repair or replacement of the vinyl.

DO NOT operate the curtain if the vinyl is ripped or torn, as it could snag on the carrier assemblies.

The vinyl should be cleaned with a damp cloth. A cloth dampened with water will be adequate for most conditions, however, for heavier dirt or spots, a specific vinyl cleaner can be used.

This Model #4040 Top Roll Divider Curtain has been custom manufactured according to the Owner's/Architect's specifications. When operated and maintained with proper care, this curtain should provide years of safe, trouble free service.



Top Roll Divider Curtain



ATTENTION: MAINTENANCE DEPARTMENT

To confirm that you have received maintenance and warranty information, and to better serve you if you contact us, please fill out the following information and fax or mail to the address below.

Please refer to the facility name and/or the installation company below when you contact Performance Sports Systems, and include it on any correspondence.

I have received the maintenance and warranty information provided by Performance Sports Systems on the Top Roll Curtain.

Facility/School Name: _____

Installation Date: _____ Installed by: _____

Maintenance Dept. Contact: _____

Signature: _____ Date: _____

Fax to: 1-317-774-9841

Attn: Customer Service

Or

Mail to: Performance Sports Systems

Attn: Customer Service

9200 E. 146th St., Ste. A

Noblesville, IN 46060

800-848-8034



Gared Holdings, LLC

Performance Sports Systems
9200 E. 146th Street
Noblesville, IN 46060

800-848-8034
www.perfsports.com

Gared Sports
707 North 2nd Street
St. Louis, MO 63102

800-325-2682
www.garedsports.com