

**4002 MOTOR DATA:**

3/4 HP, 120 VOLT, SINGLE PHASE  
WITH KEY SWITCH AND RECEPTACLE.

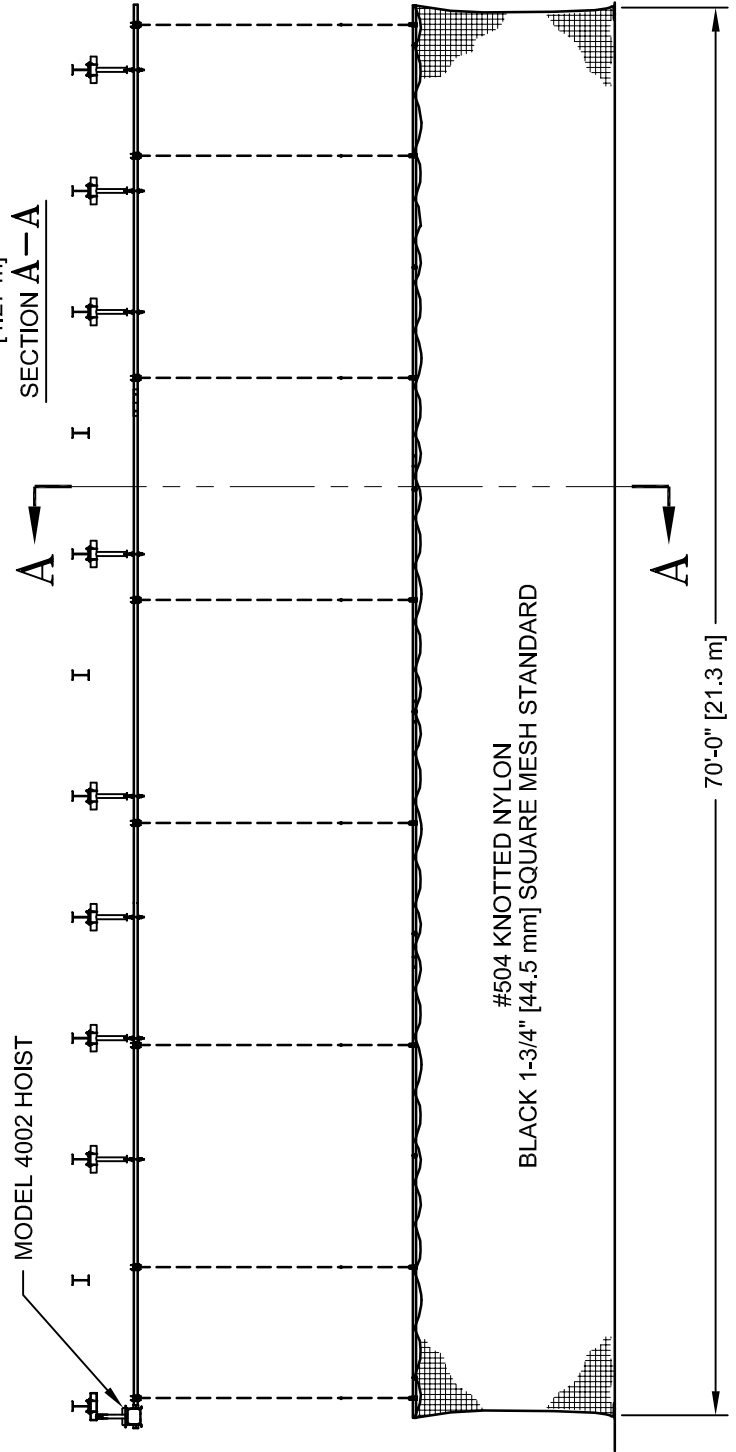

REVISION		
REV.	DATE	BY
A	01/05/12	JJC

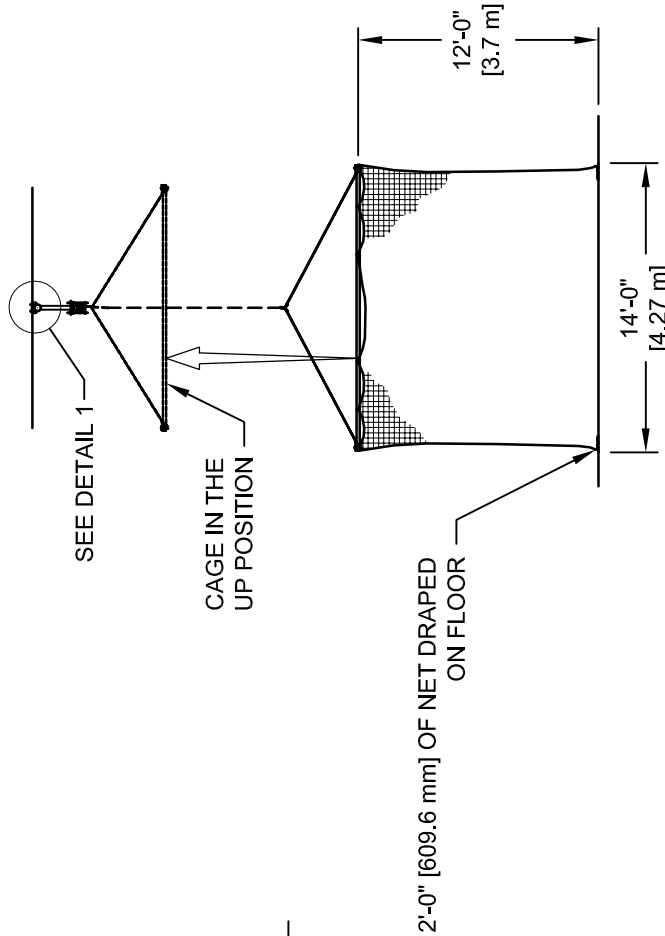
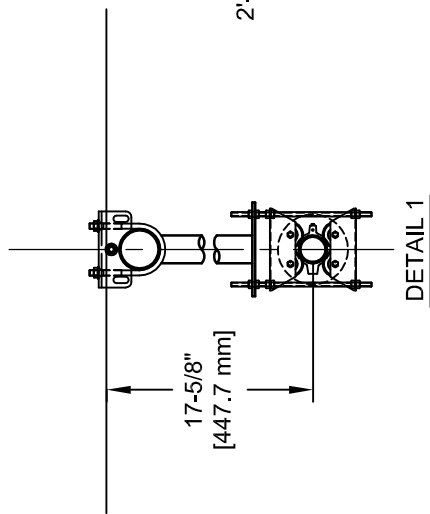

**Gared Holdings, LLC**  
9200 E. 146th St. Noblesville, IN 46060

THIS DOCUMENT CONTAINS TRADE SECRET AND OTHER MATERIALS WHICH ARE PROTECTED BY CONFIDENTIALITY NOTICE AND AGREEMENT AND BY COPYRIGHT. ANY USE OR COPYING OF THIS DOCUMENT EXCEPT AS AUTHORIZED BY GARED HOLDINGS, LLC IS STRICTLY PROHIBITED.

**BATTING CAGE**

DRAWN	CONNERLEY	DATE	05/09/03	MATERIAL	N/A
APPROVED	JJC	DATE	05/09/03	FINISH	N/A
FILE LOC. Q:\Final Release\Specifications				DWG. NO.	4081-70
SIZE	SCALE	SHT. NO.	PART NO.	REV	
A	NONE	1 OF 1	4081-70	A	



## **MODEL 4081-70**

### **BATTING CAGE**

#### **OVERHEAD SUPERSTRUCTURE**

The model 4081-70 Batting Cage is supported from the roof structure by directly attaching to the underneath side of the roof truss or by attaching to Uni-strut, 4/O Chain, or 3 1/2" O.D. horizontal and 2 3/8" O.D. vertical structural tubing supplied by PSS. Bridge pipe will be required when truss spans exceed 14'. Superstructure shall be furnished with standard black finish. If special finish coat is required, specify final painting by painting contractor.

#### **MATERIAL**

Custom size of cage shall be 10'-0" high x 12'-0" wide by 70" long. Contact factory for special sizes. Cage shall be constructed with #504 black 1 3/4" square mesh. Two Velcro corners allow one sidewall to be raised for use as a golf cage.

#### **DRIVE / SUPPORT STRUCTURE**

The model 4081-70 Batting Cage shall be operated by a PSS 4002BC curtain hoist. This curtain hoist shall drive a continuous 2-3/8" O.D. drive shaft. The cage shall be lifted by means of 1/8" galvanized aircraft cable. Lift cables shall be spaced at no greater than 12'-0" center to center. The cable shall be taken up on individual reels located on the drive shaft.

The drive shaft shall be supported by a carrier assembly spaced no greater than 12'-0" center to center. The carrier shall consist of a formed bracket with two rubber wheels on which the drive shall rotate.

Cage support frame shall be constructed of 1-7/8" O.D. steel tubing. Support frame shall be furnished with standard black finish. If special finish coat is required, specify final painting by painting contractor. The support frame may be lowered to the floor while placing the four sides of netting on top of the frame to allow for compact storage.

#### **ACCESSORIES**

Compatible hoist is the model 4002. Hoist can be used with wireless remote operator or the TSC Total System Control. Wireless remote and TSC sold separately.