



Peak Fold & Slope Fold

Models: 4025



Operation and Maintenance Instructions

.....
Please read all instructions before attempting installation or operation of these units
.....

SAVE THESE INSTRUCTIONS FOR FUTURE USE

PUBLICATION No.
7 0 1 7 5 1 1 1 6



Model 4025 Peak or Slope Fold Curtain



Table of Contents

<u>Section</u>	<u>Page No.</u>
Introduction	2
Cautions and Warnings	3
Unit Operation	4
Maintenance	5
Wiring Diagram	6



Model 4025 Peak or Slope Fold Curtain



Introduction

Thank you for your purchase of a Model 4025 gymnasium divider curtain. To ensure that our equipment will provide years of use to you, we are including this operation and maintenance guide. This guide will provide information on the proper operating procedures and preventative maintenance of your divider curtain.

It is recommended that an individual who has been properly trained operate this gymnasium divider curtain. No one under the age of 18 should attempt to operate this unit unless properly supervised.

To prevent normal wear and tear from shortening the life of the unit, preventative maintenance inspections and repairs should be performed at least once per year. If the units are subject to high or unusual usage, inspections should be scheduled to occur more frequently. If items are found to be nonconforming, replacements can be ordered from Performance Sports Systems, Gared Sports or one of our authorized dealers. When contacting PSS or Gared Sports, please have information regarding the dealer/installer who sold the unit, the name of the project, and any applicable warranty information.



Model 4025 Peak or Slope Fold Curtain



Read and understand the following warnings to prevent possible personal injury and potential damage to the equipment during assembly, setup, and operation.

WARNING

BEFORE OPERATING DIVIDER CURTAIN MAKE SURE THE AREA AROUND AND UNDER THE CURTAIN IS CLEAR OF OBSTRUCTIONS, EQUIPMENT, AND PEOPLE. MAKE CERTAIN NO PERSONS ARE NEAR THE CURTAIN DURING OPERATION. FAILURE TO FOLLOW THIS PROCEDURE COULD RESULT IN EQUIPMENT DAMAGE AND/OR SERIOUS PERSONAL INJURY

701955081

CAUTION

ONLY TRAINED AND AUTHORIZED PERSONNEL SHOULD OPERATE THIS EQUIPMENT. OPERATION BY UNTRAINED OR UNAUTHORIZED PERSONNEL MAY RESULT IN DAMAGE TO THE CURTAIN OR CURTAIN STRUCTURE AND/OR INJURY TO ANYONE NEAR THE CURTAIN.

ALWAYS MAKE SURE AREA AROUND AND BELOW THE CURTAIN IS CLEAR OF PERSONNEL AND OBSTACLES BEFORE OPERATING THE DEVICE.

NEVER STAND DIRECTLY UNDER THE CURTAIN DURING OPERATION.

OPERATOR MUST KEEP CURTAIN IN VIEW AT ALL TIMES DURING OPERATION.

KEY SWITCH OR CONTROL PAD MUST BE MOUNTED IN CLEAR VIEW OF THE CURTAIN.

NEVER LEAVE KEY IN KEY SWITCH UNATTENDED.

NEVER SWING OR SWAY THE CURTAIN.

NEVER HANG FROM SIDES OR BOTTOM BATTEN OF CURTAIN DURING OPERATION OR WHEN CURTAIN IS IN THE LOWERED POSITION.

CAUTION SHOULD BE EXERCISED AT ALL TIMES WHEN OPERATING THE CURTAIN.

ALWAYS FOLLOW PROPER SAFETY RULES.



Model 4025 Peak or Slope Fold Curtain



Operation

It is very important that this divider curtain be operated by AUTHORIZED PERSONNEL ONLY. This curtain has been manufactured with safety in mind, but even the safest equipment can be damaged or cause damage to a person or persons when operated by unauthorized or untrained users.

- Tremendous force is created when this curtain is in motion.
- Only authorized personnel may operate curtain.
- Care must be taken to make sure the curtain and areas above and below the curtain are free and clear of any obstructions.
- Do not stand directly below the curtain when raising or lowering.
- Never swing or sway curtain.
- Structure and motor units were designed to lift the weight of the curtain only.
- Never hang from sides or bottom of curtain during operation or when curtain is in the lowered position.
- Never attach or place foreign objects on the curtain.

OPERATION OF THE MODEL #25 SLOPE FOLD & PEAK FOLD DIVIDER CURTAIN:

1. The key switch used to control the up/down motion of this curtain must be flush mounted on a wall that gives the operator a clear and full view of the curtain. Never operate the curtain if conditions do not allow for a clear and full view of the curtain.
2. The curtain may be raised or lowered by turning the key to the appropriate “Up” or “Down” position, as indicated on the switch cover plate.
3. The key that operates the curtain must remain in the possession of the authorized operator.

NEVER LEAVE THE KEY UNATTENDED IN THE KEY SWITCH.

4. The motors that control the movement of the curtain have been programmed to stop the curtain at a predetermined “up” and “down” position. Should the curtain stop before it reaches these predetermined positions the motors may have over heated and need to cool off. Allow the divider to rest for approximately 20 minutes and try to run again. If the divider still does not run contact your dealer or installation company immediately.

This divider curtain has been custom manufactured according to the Owner’s/Architect’s specifications. When operated and maintained with proper care, this curtain should provide years of safe, trouble-free service.



Model 4025 Peak or Slope Fold Curtain



Notes:



Model 4025 Peak or Slope Fold Curtain



Maintenance

!!!ALWAYS DISCONNECT POWER SOURCE BEFORE PERFORMING ANY MAINTENANCE CHECK OR OPERATION ON THIS EQUIPMENT!!!

STRUCTURE:

We recommend a yearly inspection (or more frequently depending on usage) of the nuts and bolts, checking for tightness.

MOTOR:

The motor that operates your divider curtain does not require any maintenance. We do recommend however, that the limit switches be checked on a regular basis to ensure the settings are accurate.

CURTAIN VINYL:

The curtain vinyl should be checked on a regular basis for rips or tears. Should the vinyl become ripped or torn, it must be repaired or replaced. Contact your dealer or installation company for information on repair or replacement of the vinyl.

DO NOT operate the curtain if the vinyl is ripped or torn, as it could snag on the carrier assemblies.

The vinyl should be cleaned with a damp cloth. A cloth dampened with water will be adequate for most conditions, however, for heavier dirt or spots, a specific vinyl cleaner can be used.

Wiring Diagram

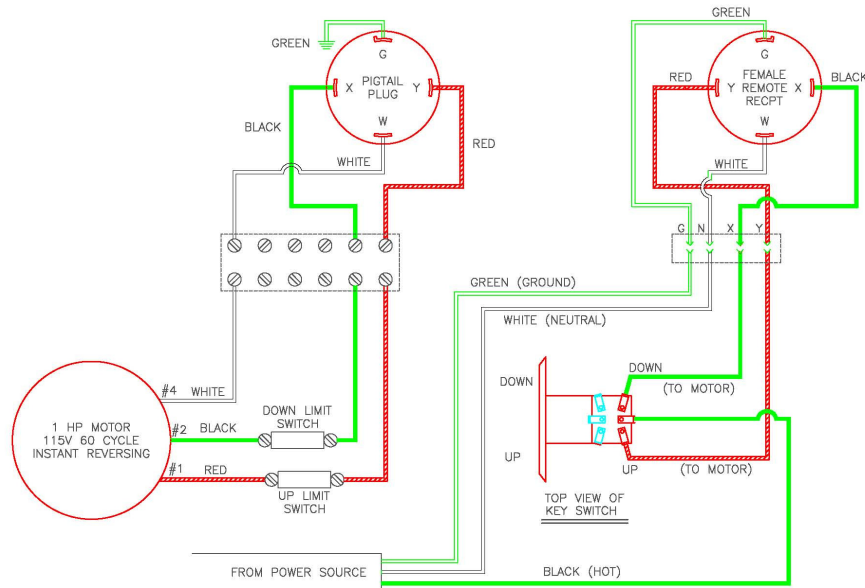

Figure 1. Key switch wiring diagram.

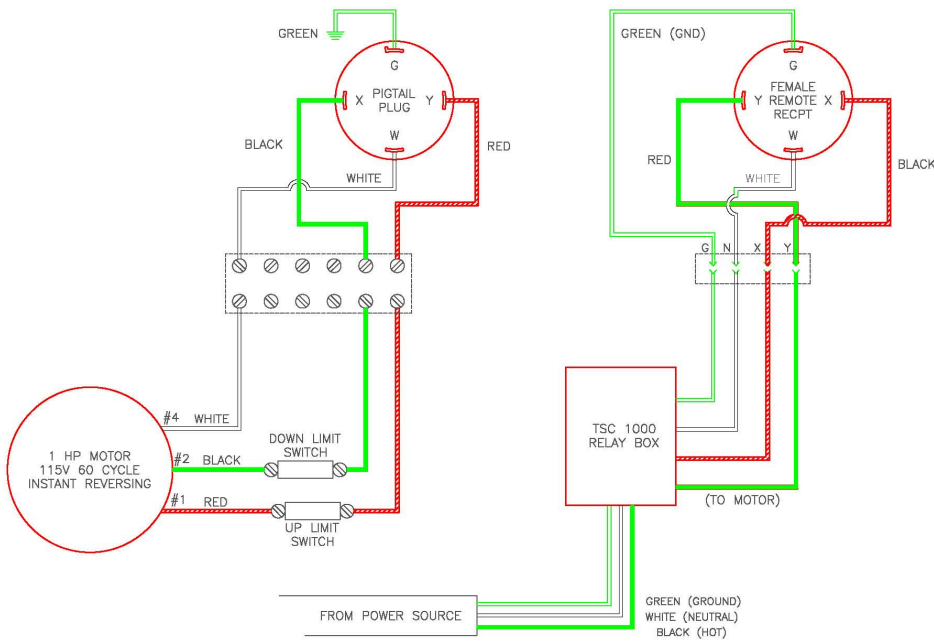

Figure 2. TSC 100 wiring diagram.



Model 4025 Peak or Slope Fold Curtain



ATTENTION: MAINTENANCE DEPARTMENT

To confirm that you have received maintenance and warranty information, and to better serve you if you contact us, please fill out the following information and fax or mail to the address below.

Please refer to the facility name and/or the installation company below when you contact Performance Sports Systems, and include it on any correspondence.

I have received the maintenance and warranty information provided by Performance Sports Systems on the Top Roll Curtain.

Facility/School Name: _____

Installation Date: _____ Installed by: _____

Maintenance Dept. Contact: _____

Signature: _____ Date: _____

Fax to: 1-317-774-9841

Attn: Customer Service

Or

Mail to: Performance Sports Systems

Attn: Customer Service

9200 E. 146th St., Ste. A

Noblesville, IN 46060

800-848-8034



Model 4025 Peak or Slope Fold Curtain



This Page Intentionally Left Blank



Model 4025 Peak or Slope Fold Curtain



Maintenance Check Sheet

Date: _____

Unit: _____

Unit Supports / Brackets / Hinges

- Tubes; dents, stress spots, etc. OK Repair Replace
- Bolts; loose, deformed, etc. OK Repair Replace
- Brackets/Hinges; bent, not rotating, etc. OK Repair Replace

Winch/Cable/Chains

- Winch; binding, loose, etc. OK Repair Replace
- Cable; fraying OK Repair Replace
- Chains; deforming, broken/bent links OK Repair Replace
- Hardware; Quick links OK Repair Replace
- Belts; fraying OK Repair Replace

Curtain Fabric

- Vinyl; torn, missing eyelets OK Repair Replace
- Mesh; torn, missing eyelets OK Repair Replace



Gared Holdings, LLC

Performance Sports Systems
9200 E. 146th Street
Noblesville, IN 46060

800-848-8034
www.perfsports.com

Gared Sports
707 North 2nd Street
St. Louis, MO 63102

800-325-2682
www.garedsports.com