

TRUSS HEIGHT FEET & (METERS)	DIM "A" Ft.-In. (Meters)	DIM "C" Ft.-In. (Meters)
18 TO 19.5 (5.48-5.94M)	4'-11" (1.50M)	6'-6" (1.98M)
19.6 TO 21.5 (5.97-6.55M)	7'-1" (2.16M)	7'-9" (2.36M)
21.6 TO 23.5 (6.58-7.16M)	9'-7" (2.92M)	7'-9" (2.36M)
23.6 TO 25.5 (7.19-7.77M)	11'-0" (3.35M)	7'-9" (2.36M)
25.6 TO 27.5 (7.80-8.38M)	14'-3" (4.34M)	7'-9" (2.36M)
27.6 TO 28 (8.41-8.53M)	16'-7" (5.05M)	7'-9" (2.36M)

DIMENSIONS ABOVE ARE ± 1/2"

NOTE:

STANDARD ATTACHMENT HEIGHTS (TRUSS HEIGHT) FOR MODEL 3209 CLAMPED UNITS ARE 18 FT. MINIMUM AND 28 FT. MAXIMUM. CONTACT PERFORMANCE SPORTS SYSTEMS FOR INFORMATION IF TRUSS HEIGHTS ARE NOT WITHIN THIS RANGE.

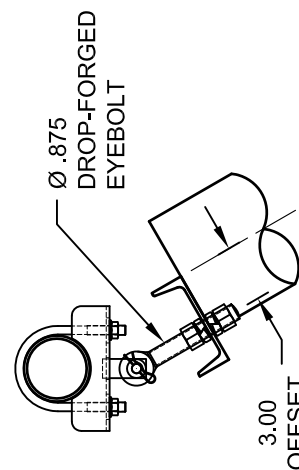
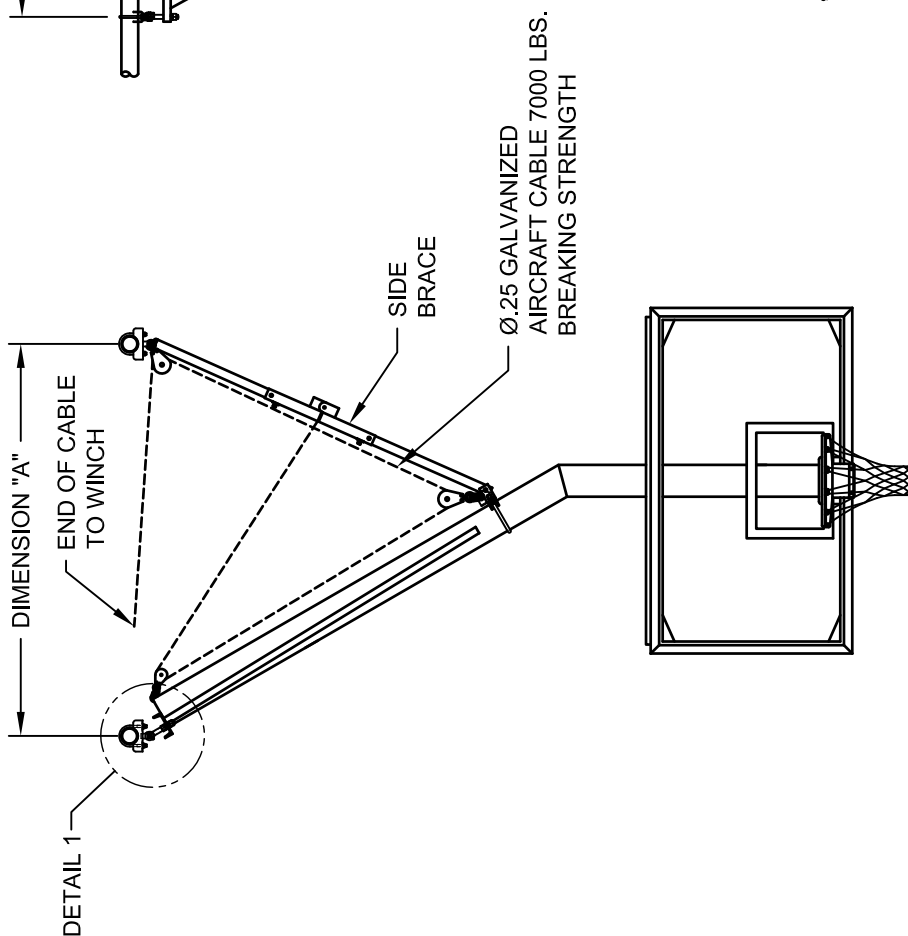

DETAIL 1

REVISION		
REV.	DATE	BY
A	12/08/03	JJC
B	12/19/06	JRM
C	05/14/08	RWP
D	06/05/09	RWP



Gared Holdings, LLC  
9200 E. 146th St. Noblesville, IN 46060

THIS DOCUMENT CONTAINS TRADE SECRET AND OTHER MATERIALS WHICH ARE PROTECTED BY CONFIDENTIALITY NOTICE AND AGREEMENT AND BY COPYRIGHT. ANY USE OR COPYING OF THIS DOCUMENT EXCEPT AS AUTHORIZED BY GARED HOLDINGS, LLC IS STRICTLY PROHIBITED.

SIDE BRACED SIDE FOLD BACKSTOP

DRAWN	CONNERLEY	DATE	04/30/03	MATERIAL	N/A
APPROVED	JJC	DATE	04/30/03	FINISH	N/A
FILE LOC. Q:\Final Release\Specifications				DWG. NO.	3209
SIZE	SCALE	SHT. NO.	PART NO.	REV	
A	NONE	1 OF 1	3209	D	



## MODEL 3209

### **Welded Bent Post Side Braced Side Folding Basketball Backstop**

#### **Recommended Application**

This model is designed for those areas not allowing sufficient space behind the backboard for a rear brace or where clearance restrictions exist above the court. This single post unit can be used at heights from 18' to 28'.

#### **Overhead Structure**

Unit shall be supported from 3-1/2" O.D. x 0.120" wall ASTM A-500 Grade B horizontal and 2-3/8" O.D. x 12 gauge (0.109") wall ASTM A-513 vertical structural steel tubing secured to the building with heavy gauge steel stampings or weldments (as required by building conditions). When truss span widths exceed 10'-0", 3-1/2" O.D. x Schedule 40 (0.216") wall ASTM A-500 Grade B will be used for the horizontals. Spans over 14'-0" will use welded bridge pipe.

#### **Backstop**

The backstop shall be of a single post design with a main vertical mast made of 6-5/8" O.D. x 0.120" wall ASTM A-500 Grade B structural steel tubing with 2-1/2" x 1-1/2" x 14 gauge (0.083") wall ASTM A-513 rectangular steel tube sway braces miter cut and welded in place to a top horizontal 4" x 1-1/2" x 0.18" web ASTM A-36 steel channel. Main mast will be suspended from superstructure with an offset hanger 3" in front of the pivot point. Units with less than 3" offset will not be approved as equal. Backstop shall be manufactured to allow 6" vertical adjustment for plumbing of the backboard. All fittings shall be heavy gauge steel stampings or weldments. A direct goal attachment is used to transfer stress from the goal to the main mast assembly preventing strain on the backboard.

Side brace shall be 1-7/8" O.D. x 12 gauge (0.109") wall ASTM A-513 steel tubing attached to the main mast 12" to 18" above the bend in the mast pipe. When brace lengths are greater than 27'-0", side brace shall be 2-3/8" O.D. x 12 gauge (0.109") wall ASTM A-513 steel tubing. Folding brace shall be of a jackknife design with an adjustable hinge for easy installation and field adjustment. Backstop shall be raised and lowered with 1/4" galvanized aircraft cable with a breaking strength of 7000 lbs. Backstop manufactured in accordance with 1994 rule 1, section 8, stating that all parts of the backboard support system shall be at least 6" behind backboard.

All steel has a black powder coat finish, standard. Optional colors available.

#### **Accessories**

**Backboards and Goals** - See the backboards and goals section in the specification manual.

**Bank Padding** - See the accessories section in the specification manual.

**Hosits** - Either Electric hoist or manual winch is available on all folding units. See the accessories section in the specification manual.

**Certifications:** Unit meets all requirements of the NCAA and NFHS. Unit complies with the design standards of the California Department of State Architects. Unit is approved by FIBA for international Level 2 competition. Certificates of Approval available.



Subject to design change and current manufacturing practices.  
Revised April 4, 2008 ©2008 Gared Holdings, LLC