

TRUSS HEIGHT FEET & (METERS)	DIM "A" Ft.-In. (Meters)	DIM "C" Ft.-In. (Meters)
30' TO 31.9' (9.14-9.74M)	14'-11" (4.55M)	7'-9" (2.37M)
32' TO 33.9' (9.75-10.35M)	16'-11" (5.16M)	7'-9" (2.37M)
34' TO 35.9' (10.36-10.96M)	18'-11" (5.77M)	10'-9" (3.28M)
36' TO 37.9' (10.97-11.57M)	20'-11" (6.38M)	10'-9" (3.28M)
38' TO 40' (11.58-12.19M)	22'-11" (6.98M)	10'-9" (3.28M)

NOTE: DIMENSIONS ABOVE ARE ± 1/2"

STANDARD ATTACHMENT HEIGHTS (TRUSS HEIGHT) FOR MODEL 3112 CLAMPED UNITS ARE 30 FT. MINIMUM AND 40 FT. MAXIMUM. CONTACT PERFORMANCE SPORTS SYSTEMS FOR INFORMATION IF TRUSS HEIGHTS ARE NOT WITHIN THIS RANGE.

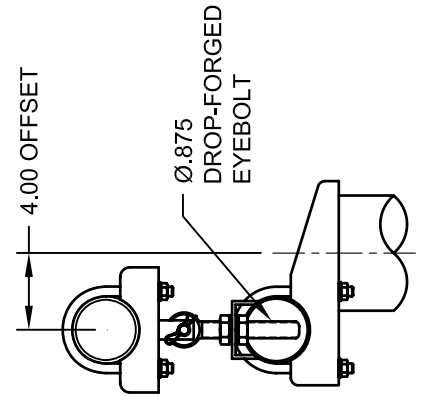
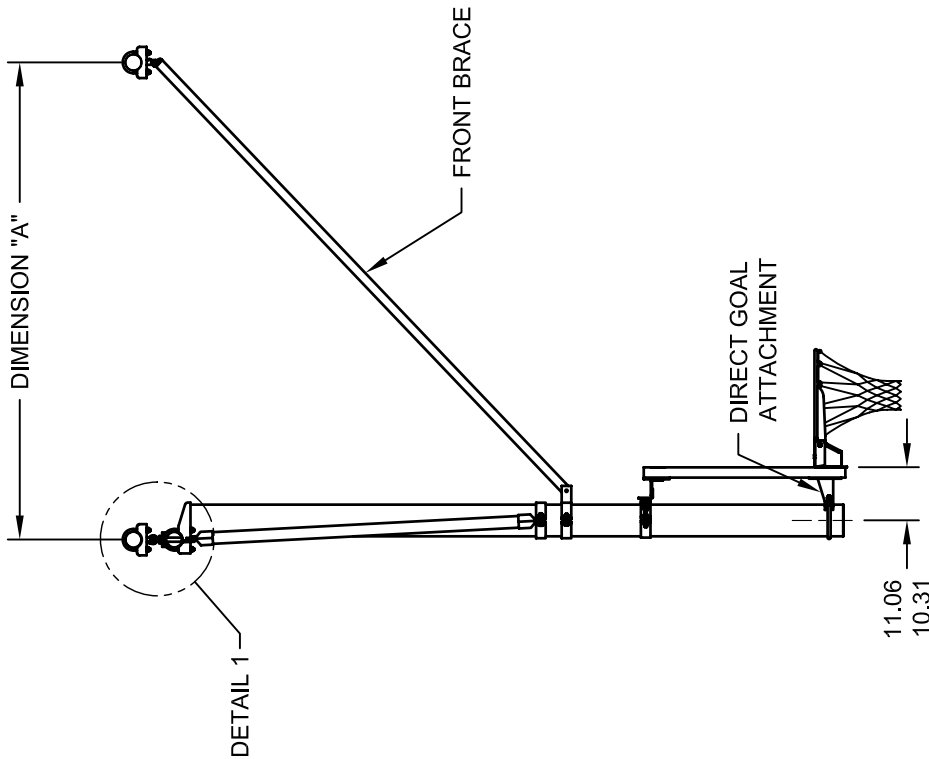

DETAIL 1

REVISION		
REV.	DATE	BY
A	12/08/03	JJC
B	03/27/04	MDL
C	12/18/06	WAE
D	05/15/08	RWP



Gared Holdings, LLC
9200 E. 146th St. Noblesville, IN 46060

THIS DOCUMENT CONTAINS TRADE SECRET AND OTHER MATERIALS WHICH ARE PROTECTED BY CONFIDENTIALITY NOTICE AND AGREEMENT AND BY COPYRIGHT. ANY USE OR COPYING OF THIS DOCUMENT EXCEPT AS AUTHORIZED BY GARED HOLDINGS, LLC IS STRICTLY PROHIBITED.

FRONT BRACED STATIONARY BACKSTOP

DRAWN	MCNARY	DATE	07/15/03	MATERIAL	N/A
APPROVED	CONNERLEY	DATE	07/16/03	FINISH	N/A
FILE LOC.	Q:\Final Release\Specifications			DWG. NO.	3112
SIZE	SCALE	SHT. NO.	PART NO.	REV	
A	NONE	1 OF 1	3112	D	



MODEL 3112

Clamped Single Post Ceiling Braced Stationary Basketball Backstop

Recommended Application

This model is designed for those areas not requiring the structure to fold into a storage position. This unit is typically used when backstop is less than 10' from the wall or when the wall will not support wall mounted or braced units. This single post unit can be used at heights from 30' to 40'.

Overhead Structure

Unit shall be supported from 3-1/2" O.D. x 0.120" wall ASTM A-500 Grade B horizontal and 2-3/8" O.D. x 12 gauge (0.109") wall ASTM A-513 vertical structural steel tubing secured to the building with heavy gauge steel stampings or weldments (as required by building conditions). When truss span widths exceed 10'-0", 3-1/2" O.D. x Schedule 40 (0.216") wall ASTM A-500 Grade B will be used for the horizontals. Spans over 14'-0" will use welded bridge pipe.

Backstop

The backstop shall be of a single post design with a main vertical mast made of 6-5/8" O.D. x 0.120" wall ASTM A-500 Grade B structural steel tubing with 2-3/8" O.D. x 12 gauge (0.109") wall ASTM A-513 steel tube sway braces clamped in place. Main mast will be suspended from superstructure with a welded steel plate offset hanger 4" in front of the pivot point, less than 4" will not be approved as equal. Backstop shall be manufactured to allow 6" vertical adjustment for plumbing of the backboard. All fittings shall be heavy gauge steel stampings or weldments. A direct goal attachment is used to transfer stress from the goal to the main mast assembly preventing strain on the backboard.

Ceiling brace shall be 1-7/8" O.D. x 12 gauge (0.109") wall ASTM A-513 steel tubing attached to the main mast 12" to 18" above the backboard. When truss heights are higher than 27'-0", ceiling brace shall be 2-3/8" O.D. x 12 gauge (0.109") wall ASTM A-513 steel tubing. Backstop manufactured in accordance with 1994 rule 1, section 8, stating that all parts of the backboard support system shall be at least 6" behind backboard.

All steel has a black powder coat finish, standard. Optional colors are available.

Accessories

Backboards and Goals - See the backboards and goals section in the specification manual.

Backboard Padding - See the accessories section in the specification manual.

Certifications

Unit meets all requirements of the NCAA and NFHS. Unit complies with design standards of the California Department of State Architects. Unit is approved by FIBA for international Level 2 competition. Certificate of Approval available.

