

FITS 3.5" O.D. OR 4" O.D. OVERHEAD PIPE STRUCTURE

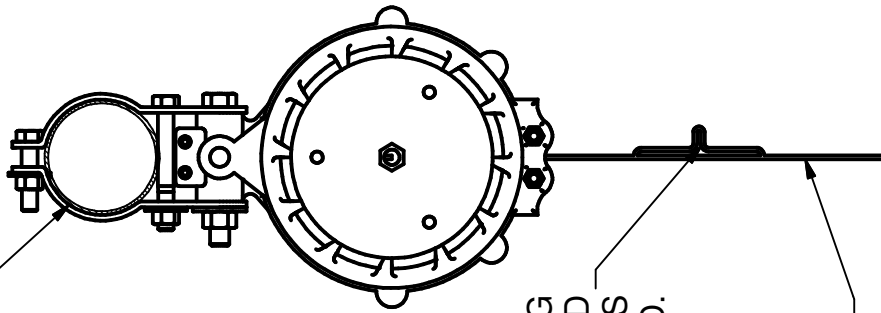

YELLOW WARNING INDICATOR EXPOSED IF SAFESTOP HAS BEEN ENGAGED.

2" WIDE NYLON BELT WITH 7300 LBS. TENSILE STRENGTH AND A 38' MAXIMUM LENGTH

BUCKLE CONNECTION

**CAUTION**

LOCKING STRAP IS RATED FOR 1000 LBS. AND HAS BEEN TESTED TO HOLD 1500 LBS. FREE FALL THRUST. THIS DOES NOT INSURE THAT OTHER COMPONENTS, SUCH AS BUILDING STRUCTURE WILL WITHSTAND THRUST LOAD.

EXISTING STRUCTURE

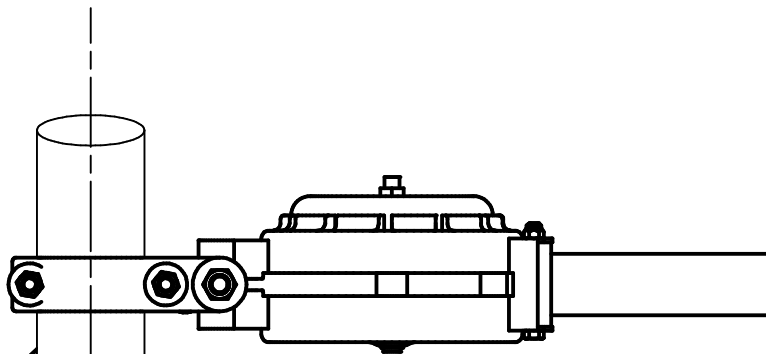

BELT

**BELT ATTACHMENT**

A	12/05/03	JJC
B	8/10/11	REM
C	2/24/2012	DAM
REV	DATE	BY



Gared Holdings, LLC  
9200 E. 146th St. Noblesville, IN 46060

THIS DOCUMENT CONTAINS TRADE SECRET AND OTHER MATERIALS WHICH ARE PROTECTED BY CONFIDENTIALITY NOTICE AND AGREEMENT AND BY COPYRIGHT. ANY USE OR COPYING OF THIS DOCUMENT EXCEPT AS AUTHORIZED BY GARED HOLDINGS, LLC IS STRICTLY PROHIBITED.

"SAFSTOP" SAFETY LOCKING STRAP

DRAWN	Ryan	DATE	8/10/2011	DATE ISSUED
APPROVED		DATE		

FILE LOC. Q:\Inventor Files\

SIZE	SCALE	SHT. NO.	PART NO.	REV
A		1 OF 1	1100-R000	C



## MODEL 1100

### **“SAFSTOP” BACKSTOP SAFETY LOCK**

This unit is designed to prevent free-fall of backstops due to cable, pulley, support fitting, or winch failure. Any sudden surge of speed due to failure shall instantly lock "Safstop" and hold the backstop in any position. This unit will lock backstop before it travels 12" in a free-fall. This unit is fully functional during storage, raising and lowering of backstops.

“Safstop” is attached to 3 1/2" O.D. overhead superstructure with a universal mounting-bracket that allows for tubing parallel or perpendicular to the unit. The 2" wide nylon belt has a tensile strength of 7300 lbs. and can extend 35 feet. The belt is attached to the backstop frame using a buckle connection.

“Safstop” has an automatic spring-loaded reset and does not require electricity in order to operate. “Safstop” locks by inertial force for immediate and positive setting, or centrifugal force for slower setting. Locking mechanism is contained within cast aluminum housing. "Safstop" is recommended for any backstop folded over seating.

“Safstop” is also available with different belt length. Belt will only retract 35 feet.

**MODEL 1103-45' belt length**

#### **CAUTION:**

**“Safstop” is rated for 1000 lbs. And has been tested to hold 1500 lbs. This does not insure that other components, such as building structure will withstand thrust load.**